

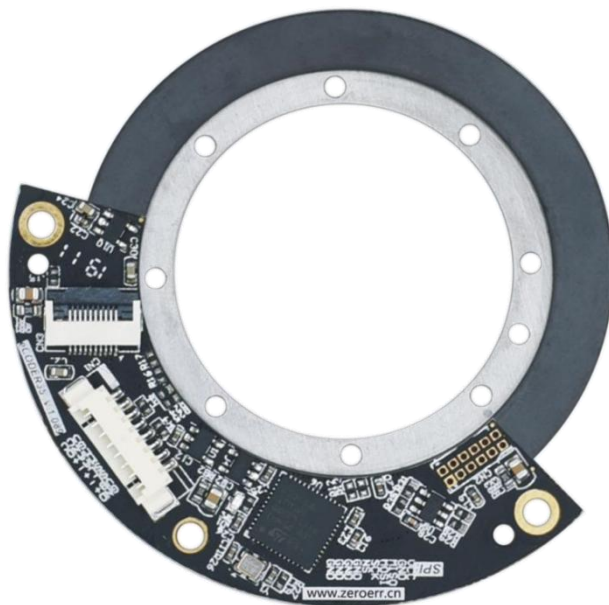

[www.zeroerr.cn](http://www.zeroerr.cn)

# eCoder 编码器用户手册 V2.4

## eCoder User Manual V2.4



## 基本信息 General Information

eCoder 是一种非接触式、高性能、多圈绝对式、旋转编码器。具有体积小，重量轻，可集成于有限的空间里。中空磁环，真正的绝对式位置功能和高速运算使得编码器能适用于大部分场合。eCoder 编码器由一个码盘和读头组成，分辨率可高达 21 位。

eCoder 编码器的工作温度范围在  $-40^{\circ}\text{C}$ ~ $105^{\circ}\text{C}$  中，具有很高的抗冲击和振动能力。内置监控功能，故障信息和其他状态信息可通过通信接口直接进行读取。

eCoder 编码器适用于工业领域，典型的案例就是使用在机械臂关节上，实现精准的伺服控制。

eCoder is a non-contact, high performance, multiturn absolute rotary encoder. With compact and lightweight structure, it is designed for integration into applications with limited space. A hollow ring, true absolute functionality and high-speed operation make this encoder suitable for many applications. The eCoder system consists of a magnetic ring and a readhead and offer a range of resolutions up to 21 bits per revolution.

The eCoder encoder operates in a temperature range between  $-40^{\circ}\text{C}$  and  $+105^{\circ}\text{C}$  and is highly resistant to shock and vibration. It has a built-in advanced self-monitoring function that continuously checks several internal parameters. Error reports and other status signals can be read through communication interfaces directly.

The eCoder encoder is suitable for use in industrial applications. A typical application is a robot arm joint, which can achieve precise servo control.



## 选型表 Selection Table

选型指南 Selection guide	型号 Model	eCoder11	eCoder18	eCoder20	eCoder35	eCoder45	eCoder65	eCoder35H
码盘 Magnetic ring	内径 Inner diameter (mm)	11	18	20	35	45	65	35
	外径 Outer diameter (mm)	30	33.5	33.5	55	64	84	55
	重量 Weight (g)	3.9	14.8	9.2	19.0	22.2	30.0	19.0
	厚度 Thickness (mm)	3	8.7	6.4	2.5	2.5	2.5	2.5
读头 Readhead	内径 Inner diameter (mm)	11	22	22	42	51	70	41
	外径 Outer diameter (mm)	30	34	34	67	75	96	65
	重量 Weight (g)	3.8	3.6	3.6	4.2	2.8	3.7	4.7
	最高厚度 Maximum (mm)	6	6	6	5.7	6	5.9	5.7
	弧长 ARC length	360°	360°	360°	150°	90°	77°	200°
	最高 分辨率 Maximum resolution	19	19	19	20	20	20	21

# 目 录 CONTENTS

<b>第一章 储存与使用</b> .....	<b>1</b>
<b>Chapter 1 Storage and Handling</b> .....	<b>1</b>
<b>第二章 编码器尺寸及安装图</b> .....	<b>2</b>
<b>Chapter 2 Dimensions and Installation Drawings</b> .....	<b>2</b>
<b>第三章 机械安装说明</b> .....	<b>9</b>
<b>Chapter 3 Installation Instructions</b> .....	<b>9</b>
<b>第四章 电气连接</b> .....	<b>10</b>
<b>Chapter 4 Electrical Connections</b> .....	<b>10</b>
<b>第五章 LED 状态指示灯说明</b> .....	<b>11</b>
<b>Chapter 5 Status Indicator LED</b> .....	<b>11</b>
<b>第六章 技术规格</b> .....	<b>12</b>
<b>Chapter 6 Technical Specifications</b> .....	<b>12</b>
<b>第七章 编码器测量精度</b> .....	<b>15</b>
<b>Chapter 7 Accuracy of the Encoder System</b> .....	<b>15</b>
<b>第八章 串行通信技术规范</b> .....	<b>17</b>
<b>Chapter 8 Specification for Serial Communication</b> .....	<b>17</b>
8.1 概述 .....	17
General specification .....	17
8.2 通讯接口 .....	17
Communication interfaces .....	17
8.3 帧格式 .....	18
Frame format .....	18
8.4 详述 .....	19
Details of each field .....	19
8.5 发送请求说明 .....	27
Note for transmitting request .....	27
8.6 发送和接收接口电路图 .....	29

Circuit diagram of transmitter and receiver .....	29
<b>第九章 多圈功能 .....</b>	<b>30</b>
<b>Chapter 9 Multiturn Function .....</b>	<b>30</b>
9.1 多圈计数 .....	30
Multiturn counter .....	30
9.2 多圈错误 .....	30
Multiturn error .....	30
9.3 位置反馈 .....	31
Feedback position .....	31
<b>第十章 eCoder 调试器使用说明 .....</b>	<b>33</b>
<b>Chapter 10 eCoder to PC Connector Instructions .....</b>	<b>33</b>
10.1 eCoder 调试器接口定义 .....	34
eCoder to PC Connector interface definition .....	34
10.2 状态说明 .....	35
Status instructions .....	35
10.3 驱动安装 .....	36
Drive installation .....	36
<b>第十一章 编码器上位机使用说明 .....</b>	<b>37</b>
<b>Chapter 11 Encoder Software Instructions .....</b>	<b>37</b>
11.1 连接功能 .....	37
Connection .....	37
11.2 状态显示 .....	38
Status .....	38
11.3 编码器设置 .....	39
Setting .....	39
11.4 自校准功能 .....	40
Self-calibration .....	40
11.5 校准波形异常原因 .....	41
Causes of abnormal calibration waveforms .....	41

11.6 固件版本升级 .....	47
Firmware version upgrade .....	47
11.7 固件升级 .....	48
Firmware upgrade .....	48
<b>第十二章 异常处理 .....</b>	<b>51</b>
<b>Chapter 12 Exception Solutions .....</b>	<b>51</b>
<b>第十三章 附录 .....</b>	<b>54</b>
<b>Chapter 13 Appendix .....</b>	<b>54</b>
13.1 产品命名规则 .....	54
Part numbering .....	54
13.2 配件 .....	55
Accessories .....	55

# 第一章 储存与使用

## Chapter 1 Storage and Handling

储存温度

Storage temperature



-40°C 至+105°C

-40°C to +105°C

使用温度

Operating temperature



-40°C 至+105°C

-40°C to +105°C

### 注意事项

#### Attention

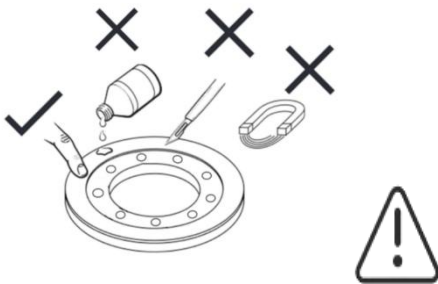

码盘磁环部分切勿靠近带磁场的物质，避免破坏码盘磁道。

The magnetic ring should not be closed to the material with magnetic field to avoid damaging the track of ring.

码盘磁环部分不可暴露在其表面磁场强度 $>20\text{mT}$ 的磁场下，因为这将会永久损坏码盘。

The magnetic ring should not be exposed to magnetic field densities higher to  $20\text{mT}$  on its surface, as this can permanently damage the ring.

码盘安装或储存时注意不能磕碰到表面磁环位置，磁环要保证不要被划伤，不可使用腐蚀性的液体清洗码盘，若表面有碎屑用无痕纸胶带将碎屑轻轻沾掉。

The magnetic ring should not be bumped or scratched its surface during installation and storage. It is not allowed to use corrosive liquids to clean the ring. If there are debris on its surface, please use non-marking paper tape to dab off it.



读头对静电十分敏感 - 注意防护

Readhead is ESD sensitive - handle with care

在没有适当的防静电保护或环境下，请不要用手直接接触电子电路、电线或者传感器区域。

Do not touch electronic circuit, wires or sensor area without proper ESD protection or outside of ESD controlled environment.



读头安装时注意元器件高度避免磕碰影响电气特性。

Pay attention to the height of the components to avoid bumping and affecting the electrical characteristics.







eCoder20 读头与码盘 (详细 2D 和 3D 图纸请前往 [www.zeroerr.cn](http://www.zeroerr.cn) 下载)

eCoder20 readhead and magnetic ring (For details see 2D and 3D drawings available at [www.zeroerr.cn](http://www.zeroerr.cn))

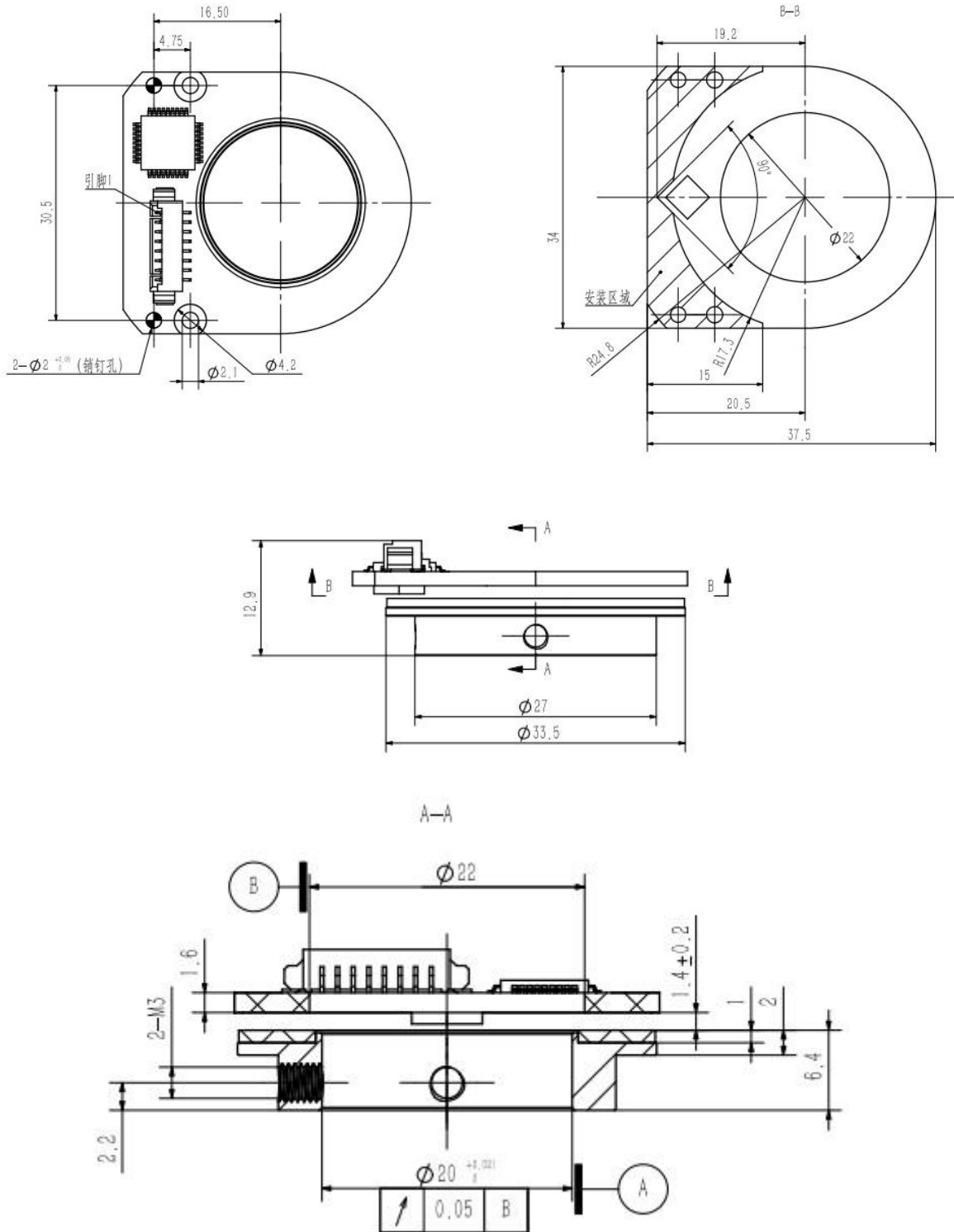

eCoder35 读头与码盘（详细 2D 和 3D 图纸请前往 [www.zeroerr.cn](http://www.zeroerr.cn) 下载）

eCoder35 readhead and magnetic ring（For details see 2D and 3D drawings available at [www.zeroerr.cn](http://www.zeroerr.cn)）

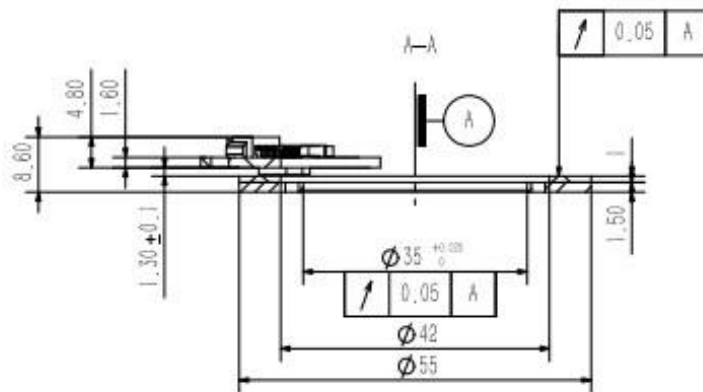
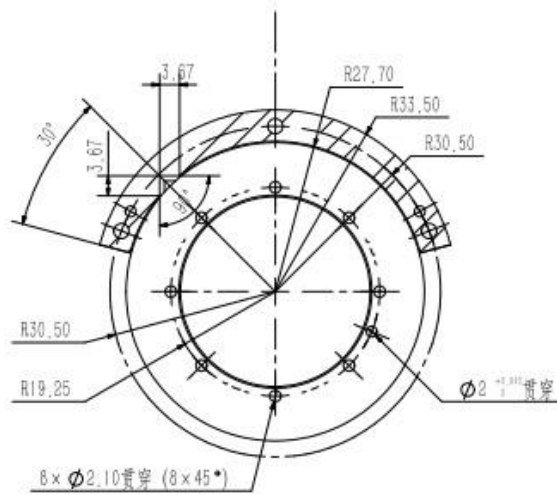
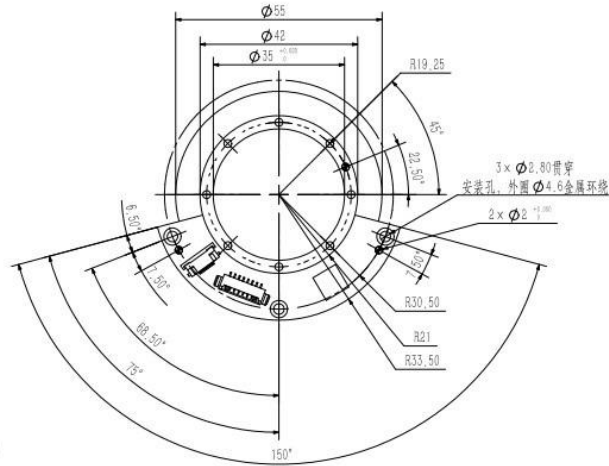

eCoder45 读头与码盘 (详细 2D 和 3D 图纸请前往 [www.zeroerr.cn](http://www.zeroerr.cn) 下载)

eCoder45 readhead and magnetic ring (For details see 2D and 3D drawings available at [www.zeroerr.cn](http://www.zeroerr.cn))

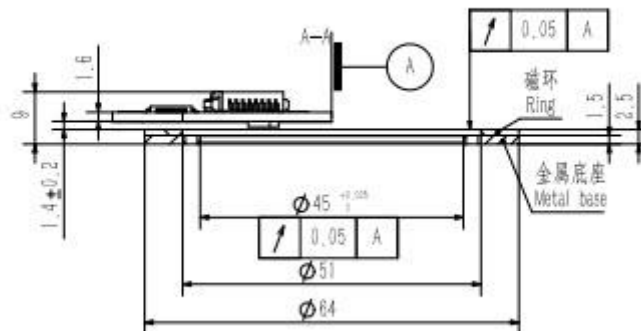
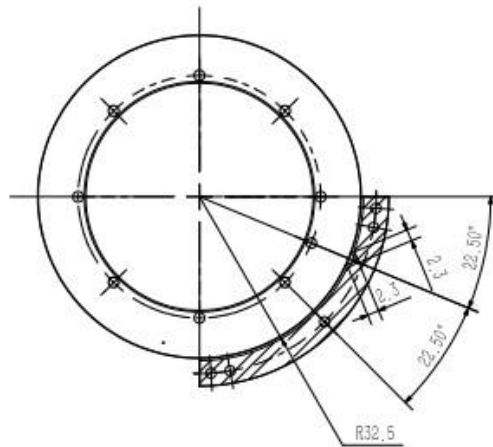
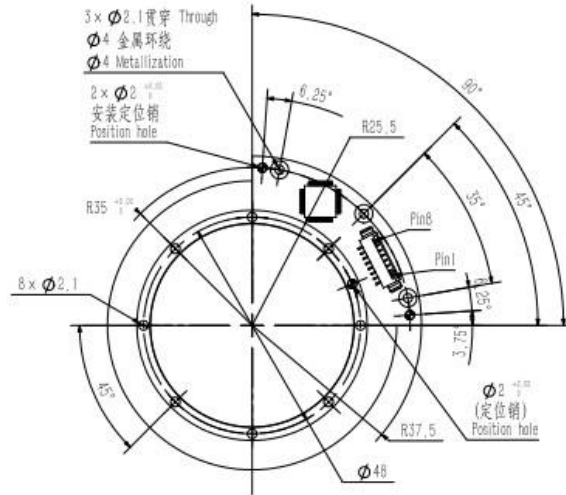

eCoder65 读头与码盘 (详细 2D 和 3D 图纸请前往 [www.zeroerr.cn](http://www.zeroerr.cn) 下载)

eCoder65 readhead and magnetic ring (For details see 2D and 3D drawings available at [www.zeroerr.cn](http://www.zeroerr.cn))

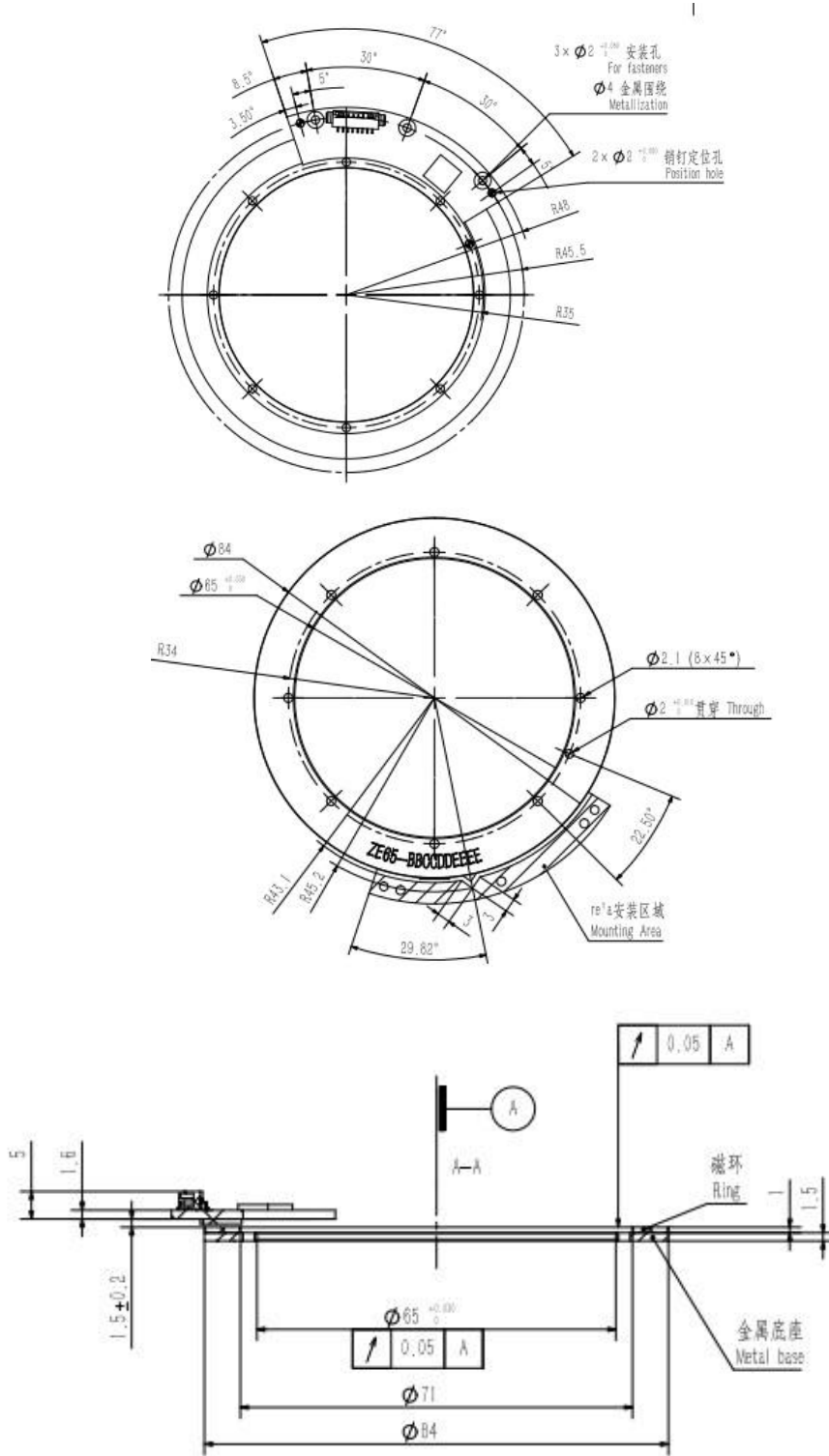

eCoder35H 读头与码盘 (详细 2D 和 3D 图纸请前往 [www.zeroerr.cn](http://www.zeroerr.cn) 下载)

eCoder35H readhead and magnetic ring (For details see 2D and 3D drawings available at [www.zeroerr.cn](http://www.zeroerr.cn))

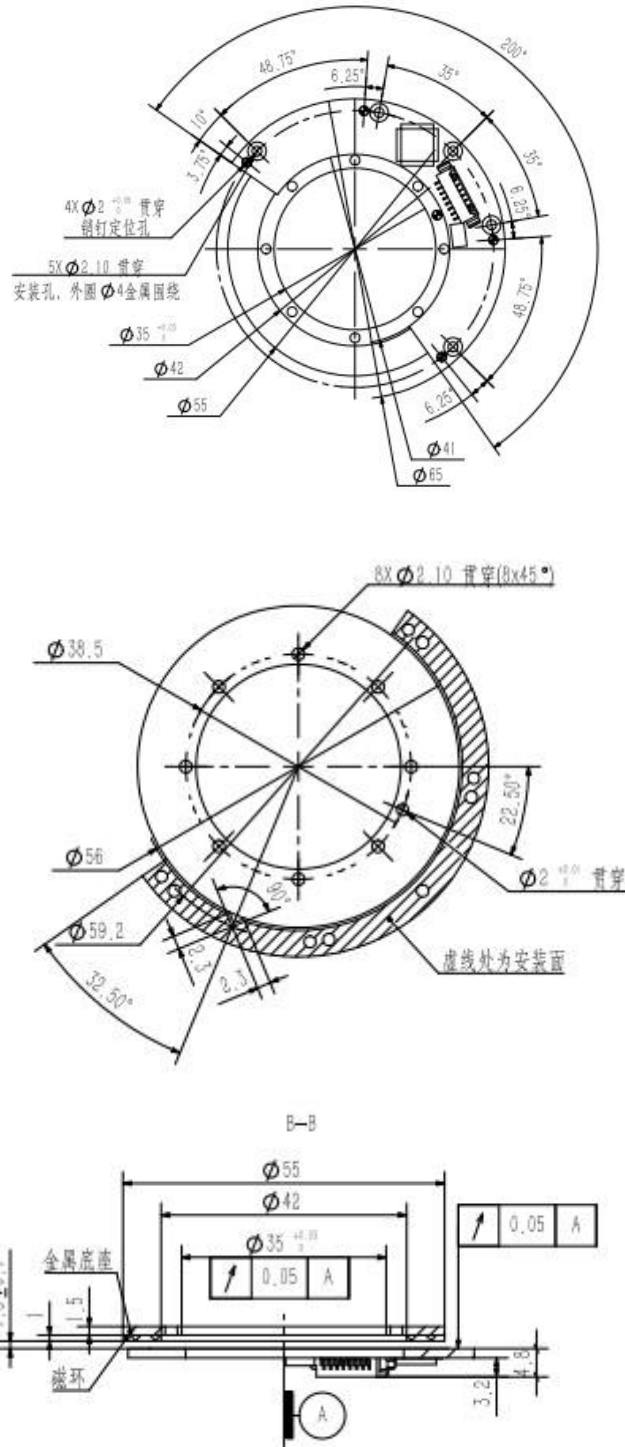

## 第三章 机械安装说明

### Chapter 3 Installation Instructions

读头安装需使用销钉进行定位，这能有效减少读头的安装误差。读头和码盘之间的距离应在 1.2-1.7mm，请参见第二章编码器尺寸及安装图上的详图 A。建议使用 PCBA 底部的镀金表面作为读头安装的参考面。如果用读头的顶部作为读头安装的参考面，必须考虑读头的厚度公差。



During readhead installation, use pins for positioning, to reduce readhead error. The distance between readhead and magnetic ring should be 1.2-1.7mm. See detail A in Chapter 2 of Dimensions and Installation Drawings. It is recommended to use the bottom gold plating section of PCBA as a reference surface for readhead installation. If the readhead top is used as the reference surface, the thickness tolerance of the readhead must be considered.

码盘的中心和读头弧形的中心点必须是同轴的，允许的误差如下表 3-1 所示，码盘安装时的偏心测量是不可少的，因为码盘的偏心误差对整体精度有着至关重要的影响。

The center of both ring and readhead arc must be coaxial. The permissible tolerances are given in table 3-1. Eccentricity measurement is essential for ring installation, as the eccentricity error plays a major role in the overall accuracy.

表 3-1 安装基本要求

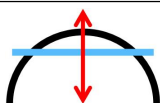
Table 3-1 Basic installation requirements

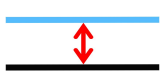
项目 Items	要求范围 Installation tolerances	示意图 Schematic drawing
允许的径向位移 Permissible radial displacement	<0.05 mm	
允许的切向位移 Permissible tangential displacement	<0.05 mm	
允许码盘非水平安装误差 Permissible non-parallel mounting error of magnetic ring	<0.05 mm	
读头至码盘距离 Readhead to ring distance	1.30 mm ± 0.1 mm (eCoder11,eCoder35,eCoder35H) 1.40 mm ± 0.2 mm (eCoder18,eCoder20,eCoder45) 1.50 mm ± 0.2 mm (eCoder65)	



## 第四章 电气连接

### Chapter 4 Electrical Connections

表 4-1 RS485 通讯引脚定义说明

Table 4-1 The RS485 communication pins description

引脚 Pin	RS485 串口通讯 RS485 Serial communication	对应连接线颜色 Corresponding Color	线缆连接器 Cable Connector
1	+5V	红色 Red	 <p>端子型号 Contact Model: Molex 50058-8000</p> <p>胶壳型号 Housing Model: Molex 51021-0800</p> <p>线缆规格 Cable Specification: UL1061, 28AWG</p>
2	GND	黑色 Black	
3	DATA+	黄色 Yellow	
4	DATA-	绿色 Green	
5	NC	蓝色 Blue	
6	NC	白色 White	
7	BAT+	橙色 Orange	
8	BAT-	紫色 Purple	

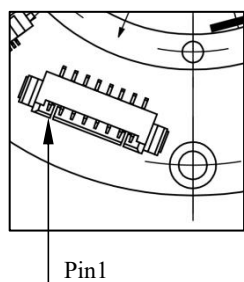

#### 8-Pin 连接器规格 8-Pin Connector Specifications:

- (1) 卧式 8Pin, 间距 1.25mm  
Horizontal 8 pin, 1.25mm pitch
- (2) 型号 Model: Molex 53261-0871



读头对静电十分敏感 - 注意防护  
Readhead is ESD sensitive - handle to care

在没有适当的防静电保护或环境下, 请不要用手直接接触电子电路、电线或者传感器区域。  
Do not touch electronic circuit, wires or sensor area without proper ESD protection or outside of ESD controlled environment.



读头安装时注意元器件高度避免磕碰影响电气特性。  
Pay attention to the height of the components to avoid bumping and affecting the electrical characteristics.



## 第五章 LED 状态指示灯说明

### Chapter 5 Status Indicator LED

表 5-1 LED 状态指示灯说明

Table 5-1 Description of LED status indicators

LED 灯状态	说明
LED light status	Description
○ 常灭 No light	未通电状态 No power supply
● 亮 Light	上电初始化状态 Power-on initialization state
○ 灭 No light	
● 常亮 Always bright	
● ● ● 慢闪 Slow flashing	正常运行状态 Normal operating state
● ● ● 快闪 Fast flashing	故障状态 Fault state



## 第六章 技术规格

### Chapter 6 Technical Specifications

#### 整体数据

##### System data

读取类型 Reading type	轴向读取 Axial reading
分辨率 Resolution	17 位-21 位和 16 位多圈计数 From 17 bit to 21 bit and 16 bit multiturn counter option
最大转速 Maximum speed	6000 RPM (eCoder35,eCoder45,eCoder65,eCoder35H) 12000 RPM (eCoder11,eCoder18,eCoder20)
磁滞现象 Hysteresis	小于分辨率单位 Less than unit of resolution

#### 电气数据

##### Electrical data

电源电压 Supply voltage	4.7 V~5.4 V
工作电流 Current consumption	105mA~125mA (eCoder11、eCoder18、eCoder20) 70mA~90mA (eCoder35、eCoder45、eCoder65) 115mA~130mA (eCoder35H)
连接器 Connection	8-Pin 连接器 8-Pin connection
电池标准电压 Battery standard voltage	3.6 V
电池报警电压 Battery warning current	<3.05 V
电池工作电流 Battery operating current	4 $\mu$ A

#### 环境数据

##### Environmental data

储存与工作温度 Operating and storage temperature	储存: -40 至 +105 $^{\circ}$ C      工作: -40 至 +105 $^{\circ}$ C Storage: -40 to +105 $^{\circ}$ C      Operating: -40 to +105 $^{\circ}$ C
外部磁场 External magnetic field	$\pm$ 20mT

对于带多圈计数功能的编码器（型号：eCoder xx M - RxxB），在电源正常供电的情况下，电池工作电流为 0  $\mu$ A。在电源供电断开，多圈电池正常供电期间，应用中需要轴转动的情况下，所支持的最大角加速度和对应的电池工作电流如表 6-1



所示。此外，表 6-2 给出了在电池供电期间以一定角速度持续运动的典型值。

For an encoder with the multi-turn counting function (Model: eCoder xx M-RxxB), the battery operating current is 0 $\mu$ A under normal power supply. When the power supply is turned off and the shaft needs to rotate during the multi-turn battery normally supply, the maximum supported angular acceleration and the corresponding battery operating current are listed in Table 6-1. Additionally, Table 6-2 gives typical values in case of enduring movement at a certain angular velocity during battery supply.

表 6-1 支持的最大角加速度和对应的电池平均工作电流

Table 6-1 :Maximum supported angular acceleration(from shaft halt), and battery average current consumption

型号 Model	$\alpha_{max}$ [ $^{\circ}/s^2$ ]	$I_{avg}$ [ $\mu A$ ]	
		typ	max
eCoder11/eCoder18/eCoder20	5000000	52	72
	1250000	26	36
	312500	14	18
	78125	7	10
	19531.25	4	6
	5000	2.5	4
	1250	2	3
eCoder35/eCoder45/eCoder65/eCoder35H	312.5	1.5	2.5
	2500000	52	72
	625000	26	36
	156250	14	18
	39062.5	7	10
	9765.625	4	6
	2500	2.5	4
625	2	3	
156.25	1.5	2.5	

**注 Note:**

1、表 6-1 所示是基于轴停止或慢速，电池电压为 3.6V 条件下的数值。

The values shown in Table 6-1 are based on the condition that the shaft halt or slow angular velocity, and the battery voltage is 3.6V.

2、在出厂默认配置下，eCoder11/eCoder18/eCoder20 支持的最大角加速度为 19531.25 $^{\circ}/s^2$ ，eCoder35/eCoder45/eCoder65/eCoder35H 支持的最大角加速度为 9765.625 $^{\circ}/s^2$ 。



Under the factory default configuration, eCoder11/ eCoder18/ eCoder20 support maximum angular acceleration is  $19531.25^\circ/s^2$ , eCoder35/ eCoder45/ eCoder65/ eCoder35H support maximum angular acceleration is  $9765.625^\circ/s^2$ .

3、针对电池供电期间可能发生的轴旋转移动，必须考虑潜在的外部因素，例如冲击和振动，因为这些事件引起的加速度可能超过正常运行时预期的最大系统加速度。如果加速度过大，会导致多圈计数错误和多圈位置信息错误。

Potential external factors, such as shock and vibration, must be considered for shaft rotation movements that may occur during battery supply, as the acceleration caused by such events may exceed the expected maximum system acceleration during normal operation. If the acceleration is too large, it will lead to multi-turn counting errors and multi-turn position information errors.

表 6-2 角速度对应的电池平均电流消耗

Table 6-2 :Angular velocity vs. battery average current consumption

型号 Model	V [RPM]	I <sub>avg</sub> [μA]
eCoder11/eCoder18/eCoder20	< 31.25	4
	< 62.5	7
	< 125	14
	< 250	26
	< 500	52
	< 1000	100
	< 2000	200
	< 4000	400
eCoder35/eCoder45/eCoder65/eCoder35H	< 15000	800
	< 15.625	4
	< 31.25	7
	< 62.5	14
	< 125	26
	< 250	52
	< 500	100
	< 1000	200
< 2000	400	
< 7500	800	

**注 Note:**

1、表 6-2 所示是基于电池电压为 3.6V 条件下的数值。

The values shown in Table 6-2 are based on the battery voltage is 3.6V.

## 第七章 编码器测量精度

### Chapter 7 Accuracy of the Encoder System

码盘的精确安装是确保整体达到良好精度的关键，通过码盘同心度（使用精密仪器测量）和使用带有精密轴承的连接轴，误差通常可以降低至如表 7-1 所示的精度值。为了提高安装后的精度，我们建议执行自校准功能。

Precise centering of the magnetic ring is the key to good overall accuracy. By minimizing the eccentricity of the ring assembly (using a gauge) and using a drive shaft with precision bearings, the error can usually be reduced to the accuracy values shown in Table 7-1. To improve the accuracy after installation, we recommend performing the self-calibration function.

表 7-1 编码器规格型号

Table 7-1 Encoder specifications

型号 Model	重复定位精度 Repeatability[ " ]	最大绝对误差 Maximum absolute tolerance[° ]
eCoder11	±15	<0.1
eCoder18	±10	<0.06
eCoder20	±10	<0.06
eCoder35	±5	<0.05
eCoder45	±5	<0.05
eCoder65	±5	<0.04
eCoder35H	±2.5	<0.02

自校准功能消除了同心度引起的误差，同心度偏差是影响编码器测量精度的最主要影响，它主要由码盘的偏心安装引起。如图 7-1 所示，当存在同心度偏差，从 A 点旋转至 B 点，会导致出现位置误差，误差值 $E=\beta-\alpha$ 。图 7-2 为旋转一圈 E 值的变化趋势。

The self-calibration function eliminates the error caused by concentricity. The concentricity deviation is the most important factor affecting the measurement accuracy of the encoder, which is mainly caused by the eccentric mounting of the ring. As shown

in Figure 7-1, when there is a concentricity deviation, rotating from point A to point B will cause a position error, and the error value  $E = \beta - \alpha$ . Figure 7-2 shows the changing trend of E value for one rotation.



图 7-1 同心度偏差旋转

Figure 7-1 Concentricity Deviation Rotation

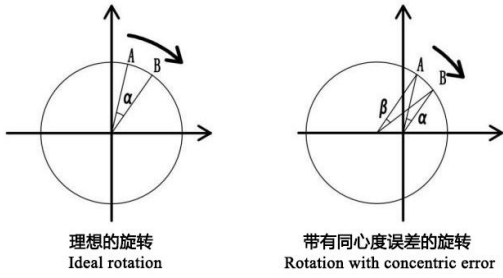

图 7-2 误差值变化趋势图

Figure 7-2 Error value change trend chart

## 第八章 串行通信技术规范

### Chapter 8 Specification for Serial Communication

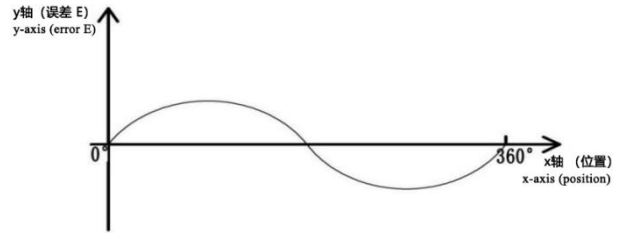
#### 8.1 概述

##### General specification

Items 项目	Specification 描述	Remarks 备注
Transmission type 传输类型	Differential line driver 差分驱动	Equivalent to RS 485 RS485
Reception type 接收类型	Differential line driver 差分驱动	Equivalent to RS 485 RS485
Transmission data 传输数据	One revolution data 单圈数据	17 bits (Max. 21bits)
	Multi-turn data 多圈数据	16 bits
Communication rate 通信速率	2.5Mbps	

#### 8.2 通讯接口

##### Communication interfaces

通讯参数 Communication parameters		
波特率 Baud rate	2.5M	
字节长度 Character length	8bits	
奇偶校验 Parity	无 None	
停止位 Stop bits	1	
流控制 Flow control	无 None	
请求通信模式 Request communication mode	被动响应通信 Passive response communication	

## 8.3 帧格式

### Frame format

#### 8.3.1. 数据读取

##### Data readout from encoder

表 8-1 读出编码器数据的帧格式

Table 8-1 Frame format for reading-out encoder data

Request	Control field											
	CM											
Transmission data from Encoder		<5 $\mu$ s	Control field	Status field	Data field							CRC field
			CM	SA	D0	D1	D2	D3	D4	D5	D6	D7

#### 8.3.2. 写 EEPROM

##### Access (Writing) to EEPROM

表 8-2 写 EEPROM 帧格式

Table 8-2 Frame format for writing to EEPROM

Request	Control field	Address field	EEPROM field	CRC field					
	CM	AF	EF	CRC					
Transmission data from Encoder					<20 $\mu$ s	Control field	Address field	EEPROM field	CRC field
						CM	AF	EF	CR

表示根据请求更改其信息的字段

CM 作为其请求的相同内容传输。

Mean the field that changes its information depending on the request

CM is transmitted as the same content of its request.



### 8.3.3. 读取 EEPROM

#### Access (Readout) from EEPROM

表 8-3 读 EEPROM 帧格式

Table 8-3 Frame format for readout from EEPROM

Request	Control field	Address field	CRC field					
	CM	AF	CRC					
Transmission data from Encoder				<20 $\mu$ s	Control field	Address field	EEPROM field	CRC field
					CM	AF	EF	CR

表示根据请求更改其信息的字段

CM 作为其请求的相同内容传输。

Mean the field that changes its information depending on the request

CM is transmitted as the same content of its request.

## 8.4 详述

### Details of each field

#### 8.4.1. 控制域(CM)

##### Control field (CM)

控制域结构如表 8-4 所示。

The structure of Control field is shown in Table 8-4.

表 8-4 控制域结构

Table 8-4 Structure of control field

Start bit	Sink code			Data ID code				ID parity	Delimiter
0	0	1	0	dc0	dc1	dc2	dc3	dc4	1

(1) 起始位：固定。

Start bit: Fixed.

(2) Sink 码：固定。

Sink code: Fixed.



(3) 数据 ID 代码：通过指定表 8-5 所示的一个数据 ID 代码，将表 8-7 所示的数据从编码器中进行传输。

根据表 8-5 所示的应用指定数据 ID 代码。例如，切勿使用数据 ID 代码进行复位，替代使用数据 ID 代码进行读数。

Data ID code: By means of designating one of Data ID code shown in Table 8-5, the data shown in Table 8-7 is transmitted from Encoder.

Designate the Data ID code according to the application shown in Table 8-5. For example, never use Data ID code for Reset instead of Data ID code for Readout.

(4) ID 奇偶校验：这是数据 ID 码的奇偶校验。

ID parity: This is the Parity for Data ID code.

(5)分隔符：固定。

Delimiter: Fixed.

表 8-5 数据 ID 代码表

Table 8-5 List of data ID code

Application	Data ID	Code				Parity
		dc0	dc1	dc2	dc3	dc4
Readout of data	Data ID 0 (0x02)	0	0	0	0	0
	Data ID 1 (0x8A)	1	0	0	0	1
	Data ID 2 (0x92)	0	1	0	0	1
	Data ID 3 (0x1A)	1	1	0	0	0
Writing to EEPROM	Data ID 6 (0x32)	0	1	1	0	0
Readout from EEPROM	Data ID D (0xEA)	1	0	1	1	1
Reset	Data ID 8 (0xC2)	0	0	0	1	1
	Data ID C (0x62)	0	0	1	1	0

### 8.4.2. 状态域(SA)

#### Status field (SA)

状态域结构如表 8-6 所示。

The structure of status field is shown in Table 8-6.

表 8-6 状态域结构

Table 8-6 Structure of status field

Start bit	Information				Encoder error		Communication alarm		Delimiter
0	sd0	sd1	sd2	sd3	er0	er1	cl0	cl1	1

(1) 起始位：固定。

Start bit: Fixed.

(2) 信息：全部固定为“0”。

Information: All are fixed to "0".

(3) 编码器错误：当编码器出现任何错误时发送逻辑“1”。

Encoder error: Logic “1” is transmitted when any error occurs in Encoder.

Bit	er0	er1
Logic when the error occurs	1	1
Description of error	Counting error	Logic-OR of Multi-turn error, Battery error and Battery alarm is transmitted.

(4) 通讯报警：全部固定为“0”。

Communication alarm: All are fixed to "0".

(5) 分隔符：固定。

Delimiter: Fixed.

### 8.4.3. 数据域

#### Data field (D0~D7)

数据 ID 代码与数据域的关系如表 8-7 所示。



The relation between Data ID code and Data field is shown in Table 8-7

表 8-7 数据域列表  
Table 8-7 List of Data field

Data ID code	D0	D1	D2	D3	D4	D5	D6	D7
Data ID 0 (0x02)	AS0	AS1	AS2					
Data ID 1 (0x8A)	AM0	AM1	AM2					
Data ID 2 (0x92)	EI							
Data ID 3 (0x1A)	AS0	AS1	AS2	EI	AM0	AM1	AM2	AMC
Data ID 8 (0xC2)	AS0	AS1	AS2					
Data ID C (0x62)	AS0	AS1	AS2					

注：上表中空白表示不传输数据。

Note: Blank in above table means no data to be transmitted.

AS0~AS2: 一圈的绝对数据

AS0~AS2: Absolute data in one revolution.

在总共 24 位的帧中，AS0 位于低位，AS2 位于高位。AS2 的高 3 位始终为逻辑“0”，则有效数据共 21 位。

AS0 is located to lower bite and AS2 is located to higher bite in the frame of total 24 bits. Higher 3 bits of AS2 are always logic "0", and then the valid data consists of total 21 bits.

AM0~AM2: 多圈数据。

AM0~AM2: Multi-turn data.

在总共 24 位的帧中，AM0 位于低位，AM2 位于高位。AM2 始终为逻辑“0”，则有效数据共有 16 位。

AM0 is located to lower bite and AM2 is located to higher bite in the frame of total 24 bits. AM2 is always logic "0", and then the valid data consists of total 16 bits.

EI: 编码器 ID

EI:Encoder ID

AMC: 编码器故障(见表 8-8 所示。)

AMC: Encoder error(See Table 8-8.)

表 8-8 AMC

Table 8-8 AMC

Bit	Bit0	Bit1	Bit2	Bit3	Bit4	Bit5	Bit6	Bit7
Logic when each error occurs	1	1	1	1	1	1	1	1
Name	Rsvd	Rsvd	Counting error	Rsvd	Rsvd	Multi-turn error	Battery error	Battery alarm

各数据区结构如表 8-9 所示。

The structure of each Data field is shown in Table 8-9.

表 8-9 数据区结构

Table 8-9 Structure of Data field

Start bit	Data(LSB first) ( $0 \leq m \leq 7$ )								Delimiter
0	dm0	dm1	dm2	dm3	dm4	dm5	dm6	dm7	1

(1) 起始位: 固定。

Start bit: Fixed.

(2) 数据: 以 LSB 在前排列。

Data: Arranged with LSB first.

(3) 分隔符: 固定。

Delimiter: Fixed.

### 8.4.4 CRC 校验域(CRC)

#### CRC field (CRC)

CRC 校验域结构如表 8-10 所示。

The structure of CRC field is shown in Table 8-10

表 8-10 CRC 校验域结构

Table 8-10 Structure of CRC Field

Start bit	CRC code(LSB first)							Delimiter	
0	cr0	cr1	cr2	cr3	cr4	cr5	cr6	cr7	1

(1) 起始位：固定。

Start bit: Fixed.

(3) CRC 校验代码：该代码符合  $G(X) = X^8 + 1$  ( $X = cr0 \sim cr7$ ) 方程。

数据首先以 LSB 排列。该代码是根据除 CRC 域之外的所有域的所有位计算的，不包括起始位和分隔符。

CRC code: This code conforms to the equation of  $G(X) = X^8 + 1$  ( $X = cr0 \sim cr7$ ).

The data is arranged in LSB first. The code is calculated from all bits without Start bit and Delimiter, of all fields except CRC field.

(3) 分隔符：固定。

Delimiter: Fixed.

(4) 代码示例：

Code example:



---

Polynomial	$x^8+1$	Initial Value	0
------------	---------	---------------	---

---

CRC 校验函数  
CRC Checksum function

---

```
uint8 CRC_C(uint8 *CRCbuf, uint8 Length)
{
    uint8 CRCResult=0;
    uint8 CRCLength=0;
    while(CRCLength<Length)
    {
        CRCResult ^= CRCbuf[CRCLength];
        CRCResult = (CRCResult&0x00ff);
        CRCLength++;
        CRCResult = CRC_8X1[CRCResult];
    }
    return CRCResult;
}
```

校验函数表生成函数 Calibration function table generation functions

```
void CRC_8X1_TAB_Creat(void)
{
    uint16 i,j;
    uint8 CRCResult;
    for(j = 0; j < 256; j++)
    {
        CRCResult = j;
        for(i = 0; i < 8; i++)
        {
            if(CRCResult & 0x80)
            {
                CRCResult = (CRCResult << 1) ^ 0x01; //0x01--x^8+1
            }
            else
            {
                CRCResult <<= 1;
            }
        }
        CRC_8X1[j] = (CRCResult&0x00ff);
    }
}
```

#### 8.4.4. 地址域(AF)和 EEPROM 域(EF)

##### Address field (AF) and EEPROM field (EF)

AF 域结构如表 8-11 所示。

The structure of AF field is shown in Table 8-11.

表 8-11 AF 域结构

Table 8-11 Structure of AF field

Start bit	Address(LSB first)							Busy status	Delimiter
0	ad0	ad1	ad2	ad3	ad4	ad5	ad6	BSY	1

(1) 起始位：固定。

Start bit: Fixed.

(2) 地址：LSB 在前，EEPROM 地址范围 (0x00~0x6F)。

Address: Address of EEPROM (0x00~0x6F) with LSB first.

(3) 忙状态：可以通过忙状态检查对 EEPROM 的访问状态。

Busy status: Access state to EEPROM can be checked by Busy status.

(4) 分隔符：固定。

Delimiter: Fixed.

(5) EF：8 位数据，LSB 在前

数据域的结构参见表 8-9。

EF: 8-bit data with LSB first

The structure of Data field is equivalent to Table 8-9.



## 8.5 发送请求说明

### Note for transmitting request

功能	数据 ID	说明
Function	Data ID	Description
数据读取 Readout of data	0, 1, 2 & 3	<p>根据数据域列表（表 8-7）向编码器发送数据 ID 代码（表 8-5）。由于编码器中使用了符合 RS-485 的接收 IC, 因此通过符合 RS-485 的驱动 IC (例如 SN65HVD75) 或同等产品进行传输。</p> <p>Transmit Data ID code (Table 8-5) according to the List of Data Field (Table 8-7) to Encoder. Because the receiver IC conformable to RS-485 is used in Encoder, transmit by the driver IC conformable to RS-485 (for example, SN65HVD75) or equivalent.</p>
单圈数据复位 Reset of one revolution data	8	<p>该复位指令要求以不小于 40us 的时间间隔连续发送 10 次指令，将任一单圈位置进行复位归零。即使外接电池在电源关闭后，该位置依旧保持复位后的角度位置。</p> <p>Transmit 10 times in one sequence to Encoder with the interval of 40μs or more at stationary of the shaft. The angle position that is reset once is kept even after the power supply is turned off in spite of existing the external battery.</p>
多圈数据和错误复位 Reset of multi-turn data and all error	C	<p>该复位指令要求以不小于 40us 的时间间隔连续发送 10 次指令，将对多圈数据进行复位归零（不影响单圈数据）。同时将所有的故障标志位进行复位。</p> <p>Transmit 10 times in one sequence to Encoder with the interval of 40μs or more at stationary of the shaft. Multi-turn data is reset. (One revolution data is not reset.) All latched errors are reset at the same time.</p>



		8 位的“用户数据”可以写入指定的地址。建议通过指定“Data ID D”来确认写入是否正确。（为了确认数据，请关闭并重新打开主电源或重新指定页面。）
6		“User Data” of 8 bits can be written to the address designated. It is recommended to confirm that the writing was properly performed by means of designating "Data ID D". (For confirming the data, turn off and on the main power supply or page is specified again.)
EEPROM 访问		
Access to EEPROM		8 位的“用户数据”可以从指定的地址读出。 关于读取请求的传输方法，请参阅第 8.3.3 和 8.4.5 章。
	D	“User Data” of 8 bits can be read out from the address designated. Regarding the transmission method for Readout request, refer to Paragraphs 8.3.3 and 8.4.5.

### 协议时序参数

### Protocol timing parameters

表 8-12 协议时序参数

Table 8-12 Protocol timing parameters

	最小 Min.	一般 Typ.	最大 Max.	单位 Unit
Data ID0(0x02)0x02 指令周期 Data ID0(0x02)Instruction cycle	35	37	40	μs
Data ID3(0x1A)0x1A 指令周期 Data ID3(0x1A) Instruction cycle	55	57	60	μs
命令响应延时[t] Readhead response delay[t]	3.5	4	5	μs
Data ID8(0xC2)执行后需等待时间 Data ID8(0xC2) Wait time after execution		600		ms
Data IDC(0x62)执行后需等待时间 Data IDC(0x62)Wait time after execution		600		ms

## 8.6 发送和接收接口电路图

### Circuit diagram of transmitter and receiver

发送和接收接口电路图示例如图 8-1 所示。

An example of circuit diagram of the transmitter and receiver is shown in Figure 8-1.



图 8-1 发送和接收接口电路示例图

Figure 8-1 Example of Transmitter and Receiver Circuit

编码器传输数据时，不要向编码器发送任何请求。如果在此期间，任何请求被错误地发送给编码器，则编码器的接口电路可能会中断。编码器除了传输数据外，始终处于接收模式。

Never transmit any Request to Encoder while it transmits the data. The interface circuit of Encoder may be broken down if any Request is transmitted to Encoder by mistake during this period.

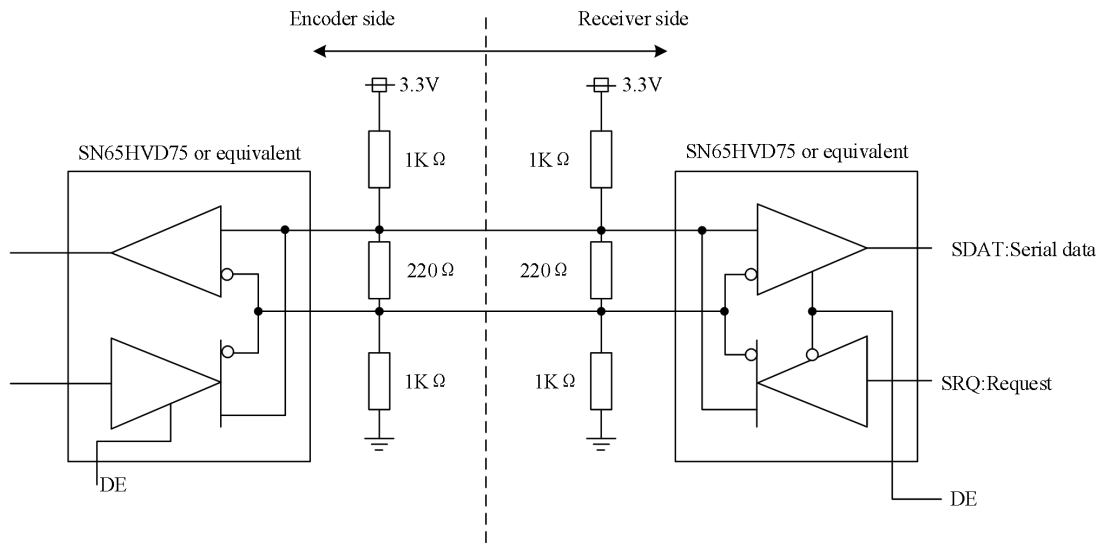
Encoder is always in the receiving mode except it is transmitting data.



## 第九章 多圈功能

### Chapter 9 Multiturn Function

#### 9.1 多圈计数

##### Multiturn counter

ZeroErr eCoder 是一款绝对式编码器，每转分辨率为 17bits（最大 21bits）和 16bits 多圈计数，总分辨率为 33bits(最大 37bits)，将绝对位置数据作为串行数据进行输出，以响应外部请求。但在未连接电池的情况下，它作为一个绝对式编码器，将每转 17 bits（最大 21 bits）的绝对位置数据作为串行数据输出，以响应外部请求。

ZeroErr eCoder is a full absolute encoder that has the resolution of 17 bits (Max. 21bits) per revolution and the multi-turn counting of 16 bits, as the total resolution of 33 bits(Max. 37bits), and transmits the output of full absolute position data as serial digital data in response to an external request. But when the battery is not connected, it functions as a full absolute encoder that transmits the output of full absolute position data with 17 bits(Max. 21bits) per revolution as serial digital data in response to an external request.

即使在停电等突然切断主电源的情况下，也可以通过连接电池来保存多圈数据和操作多圈计数器。

It is capable of saving the multi-turn data and operating the multi-turn counter by mean of connecting to a battery even when the main power supply is suddenly cut off such as for a power outage.

#### 9.2 多圈错误

##### Multiturn error

编码器在断电模式下工作时需要外接电池。在未外接电池的情况下主电源通电错误标志的详细信息，请参见表 8-8 状态标志功能说明。

当电池错误发生时，通过多圈复位功能使其恢复正常运行。

An external battery is needed when Encoder operates in the power-off mode. Refer to Table 8-8 Description of Status Flag Function for details of the error flag when the main power supply is turned on with no external battery.

When the battery error occurs, it is returned to operate normally by resetting its multi-turn data.

## 9.3 位置反馈

### Feedback position

当编码器单圈位置在边界位置发生跳变时编码器会进行多圈圈数计数。以 19Bit 分辨率编码器为例（如图 9-1 所示），19Bit 分辨率的编码器边界位置为 0 和 524287，正转是从 524287 跳变到 0，多圈圈数+1，反转是从 0 跳变到 524287，多圈圈数-1。

当前位置计算公式：

多圈绝对位置 = 多圈圈数 × 分辨率 + 单圈绝对位置。

When the single-turn position of the encoder jumps at the boundary position, the encoder will count the number of multi-turn turns. Take the 19Bit resolution encoder as an example (as shown in Figure 9-1), the boundary positions of the encoder with 19Bit resolution are 0 and 524287, the forward rotation is from 524287 to 0, the number of multi-turn turns +1, the reverse rotation is from 0 to 524287, and the multi-turn Number of laps -1.

Current position calculation formula:

multi-turn absolute position = multi-turn number of turns × resolution + single-turn absolute position.



图 9-1 位置反馈

Figure 9-1 Feedback position

## 第十章 eCoder 调试器使用说明

### Chapter 10 eCoder to PC Connector Instructions

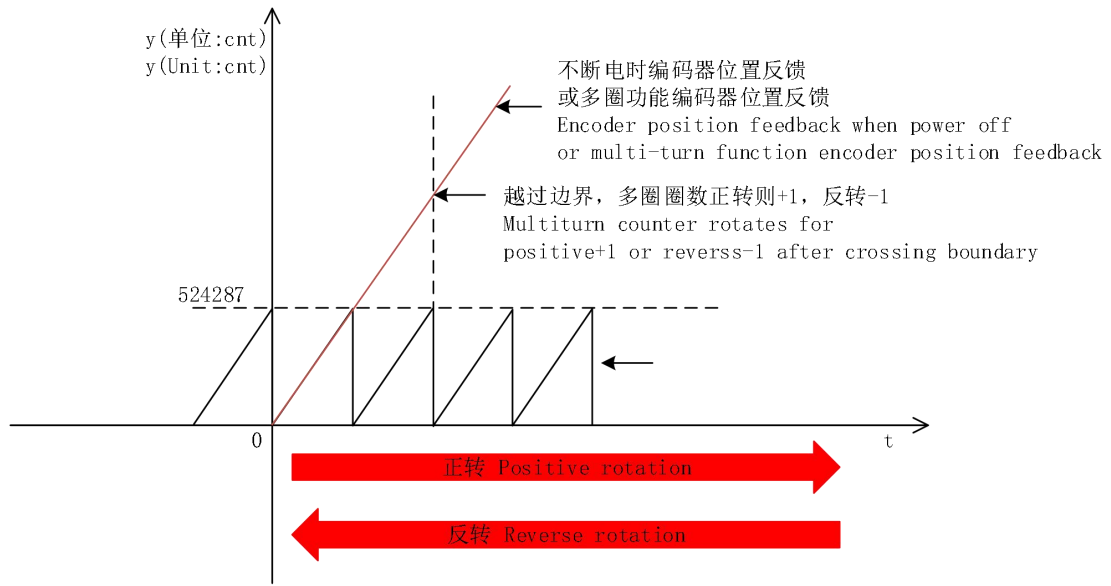
eCoder 调试器是我司专门为 eCoder 系列编码器定制的调试工具，其最高速率可达到 10M 波特率，可用来连接编码器上位机，查询编码器内部报错状态及执行校准操作。该调试器可通过 [www.zeroerr.cn](http://www.zeroerr.cn) 进行购买。调试 eCoder 系列编码器时建议使用官方原厂调试器，其他型号调试器可能存在不兼容的情况，我司不对其他型号调试器提供技术支持。

eCoder to PC Connector is a tool designed for debugging the eCoder series encoders with a maximum speed of 10M baud rate, which can be connected to the encoder software for checking the internal error status of eCoder and executing calibration. The eCoder to PC Connector can be purchased from [www.zeroerr.cn](http://www.zeroerr.cn). It is recommended to use the official original "eCoder to PC Connector" when debugging eCoder series encoders, because other models of debuggers may be incompatible. Our company does not provide technical support for other types of debuggers.



图 10-1 eCoder 调试器

Figure 10-1 eCoder to PC Connector

## 10.1 eCoder 调试器接口定义

### eCoder to PC Connector interface definition

表 10-1 接口标识

Table 10-1 Interface identification

接口标识 Interface identification	功能 Function
+5V	电源正 Power Supply DC+5V
DATA+	通讯正 DATA+
NC	保留 RESERVED
DATA-	通讯负 DATA-
GND	电源地 GND



图 10-2 接线示例图

Figure 10-2 Wiring example diagram

#### 注意事项 NOTE:

1、请务必先接入 RS485 线缆，然后插入 USB 接口，切勿带电插入 RS485 线。

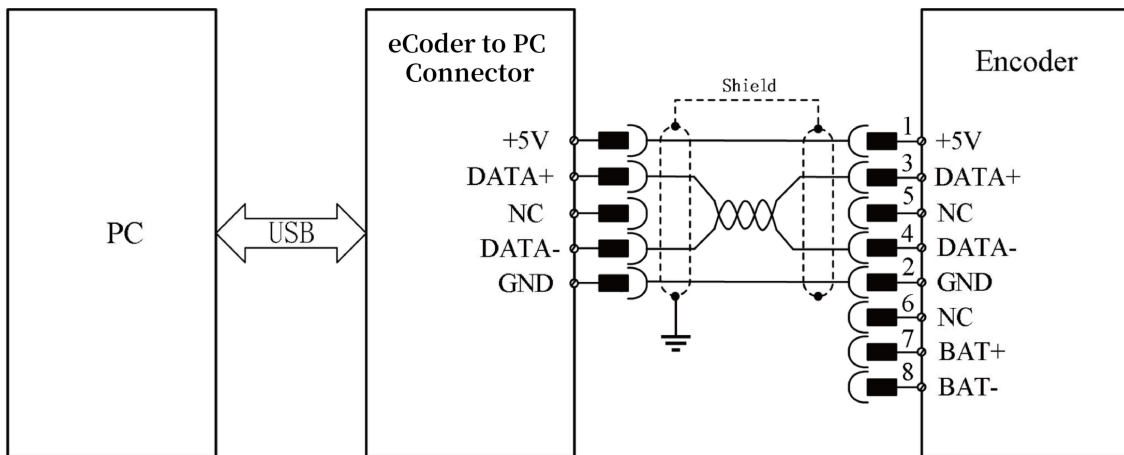
Make sure to connect the RS485 line to the eCoder first before connecting the "eCoder to PC Connector" to the PC. Do not connect the RS485 line while the eCoder or the "eCoder to PC Connector" is powered.

2、eCoder 调试器 5Pin 接线端子与 RS485 线压接时不要只压到线缆外被，需





确保与 RS485 线线芯有效压接，确保两端一一导通。

For reliable connection and smooth operation, make sure to firmly connect the RS485 line to the 5-pin terminal block of the "eCoder to PC Connector" by crimping the wire to it's core, not just the outer insulation sleeve.

3、RS485 通信线采用双绞线，单独屏蔽，eCoder 编码器采用固定 2.5Mbps 通信速率。

The RS485 communication line should adopt twisted-pair wiring with separate shielding. The eCoder use a fixed 2.5Mbps communication rate.

## 10.2 状态说明

### Status instructions

eCoder 调试器进行连接后，通电状态下电源灯常亮，表示设备正常工作且处于待连接状态，当有数据进行传输时，“TX”和“RX”指示灯则快速闪烁。

After eCoder to PC Connector is connected, where the power light displays always-on indicates the device is working normally and in the status of pending connection. When data is being transferred, the “RX” and “TX” indicators blink rapidly.

表 10-2 调试器指示灯状态

Table 10-2 Debugger indicator Status

指示灯 Indicator	工作状态 Status	颜色 Color	指示状态 Indicate Status
PWR	常亮 Always-On	红色 Red	电源指示 Power instructions
TX	闪烁 Flash	黄色 Yellow	通讯发送 Communication sending
RX	闪烁 Flash	绿色 Green	通讯接收 Communication reception

## 10.3 驱动安装

### Drive installation

USB 转 RS485 驱动安装。在我司官网下载最新 eCoder 上位机软件，解压压缩包，打开文件夹：eCoderV1.0.8\调试器驱动安装，鼠标双击驱动程序进行驱动安装（如图 10-3）。

USB to RS485 driver installation. Download the latest eCoder software on our official website, unzip the package, and open the folder: eCoderV1.0.8 \ debugger driver installation, and double click “CDM21216\_Setup” to install. (as shown in Figure 10-3).



名称	修改日期	类型	大小
CDM21216_Setup	2016/3/30 星期...	应用程序	2,075 KB
PL2303_Prolific_DriverInstaller_v1.12.0	2015/10/7 星期...	应用程序	3,631 KB



图 10-3 驱动安装

Figure 10-3 Drive installation

# 第十一章 编码器上位机使用说明

## Chapter 11 Encoder Software Instructions

### 11.1 连接功能

#### Connection

首先，点击“连接设置”按钮，打开连接界面，选择对应端口号，若端口号未刷新则点击“刷新串口号”按钮，点击“连接”，识别出编码器型号和固件编号则连接成功。

First, click the “Connect” button to open the connection interface, and select the corresponding port number. If the port number is not refreshed, click the “Refresh” button, click “Connect”, and identify the encoder model and firmware number. The connection is successful.



图 11-1 连接

Figure 11-1 Connection

## 11.2 状态显示

### Status

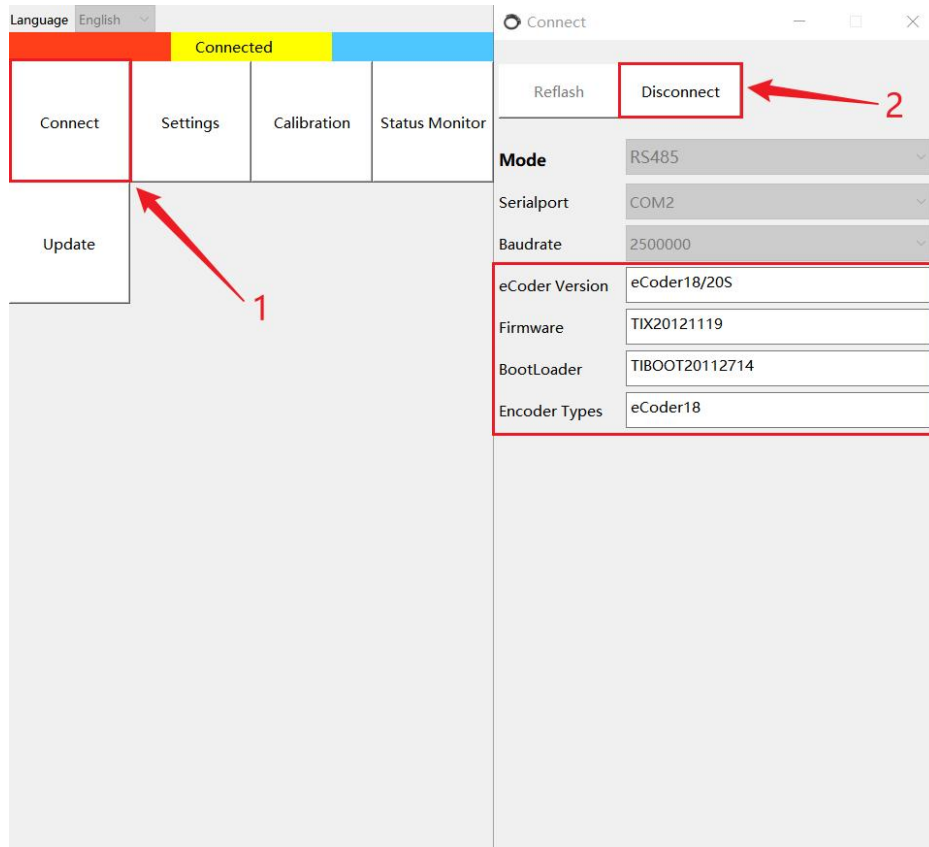
点击“状态监控”按钮，打开状态显示界面，可以看到编码器单圈、多圈位置及分辨率信息，点击“读取状态”可以实时获取编码器状态信息。状态信息参考第十二章异常处理。

Click the “Status Monitor” button to open the status display interface, you can see the encoder single-turn, multi-turn position and resolution information, click "Read Status" to obtain the encoder status information in real time. For status information, refer to Chapter 12 Exception Handling.



图 11-2 状态显示

Figure 11-2 Status

## 11.3 编码器设置

### Setting

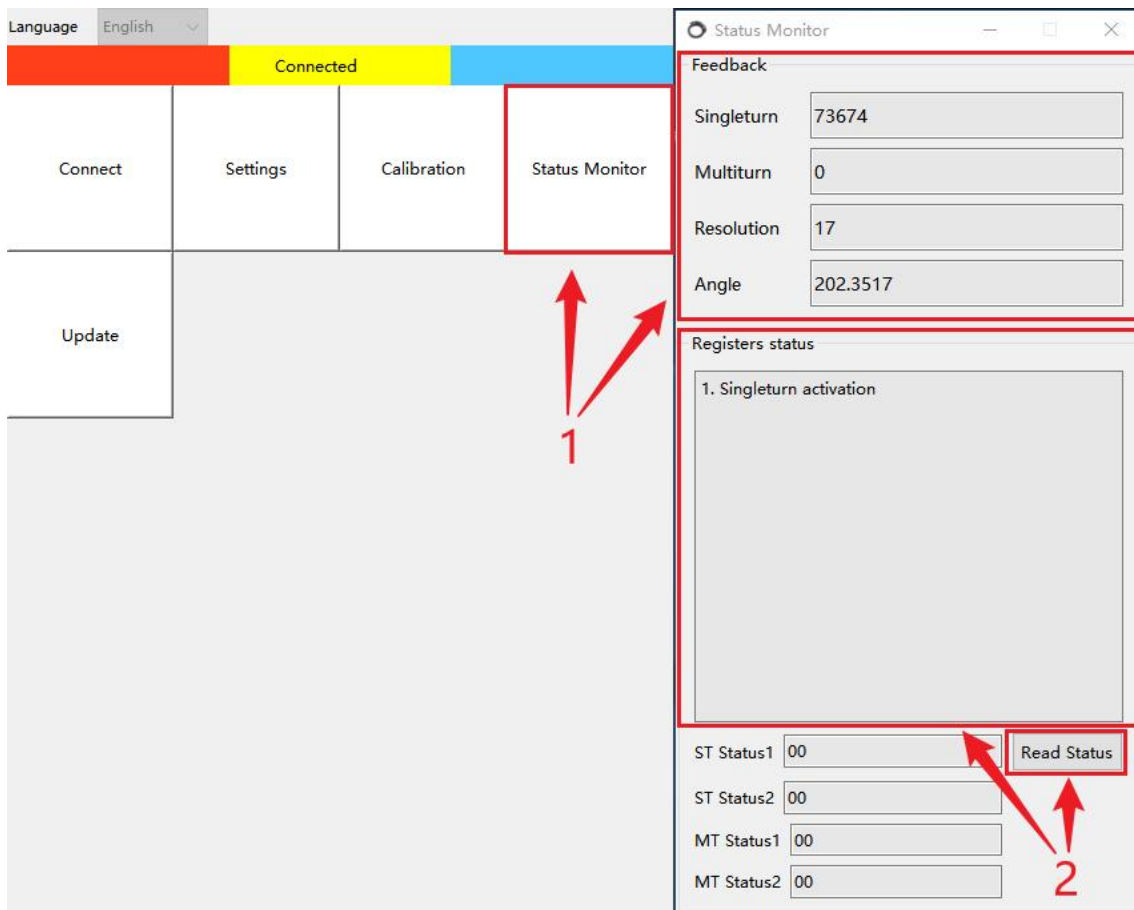
单圈复位：将编码器当前位置设置为绝对零点

Reset ST: Set the encoder to absolute zero.

多圈复位：将多圈计数清零和清除多圈报错

Reset MT: Set the multiturn counter to zero and clears the multiturn error.

设置单圈偏置：设定自定义单圈偏移值。

Set Offset: Set a custom singleturn offset value.

清除错误:故障复位。

Clear Err: Fault reset.



图 11-3 编码器设置

Figure 11-3 Setting

注：单圈复位功能是采用单圈偏置计算之后使当前单圈实际位置成为零点，即输出值=实际值-单圈偏移值。

Note: The single-turn reset function is to use the single-turn offset calculation to make the current single-turn actual position as the zero point, that is, output value = actual value - single-turn offset value.

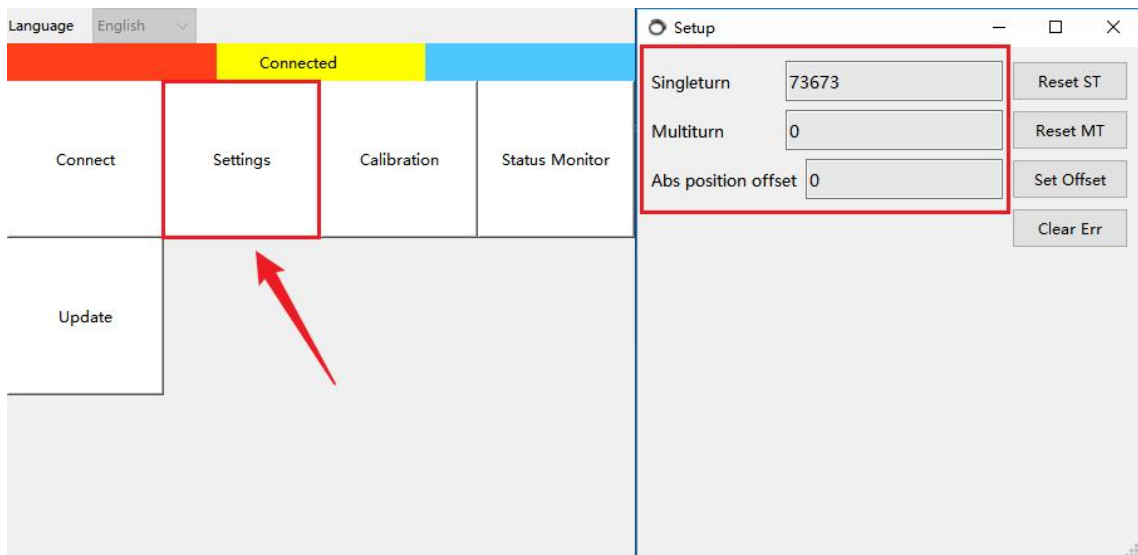
## 11.4 自校准功能

### Self-calibration

编码器在安装完成后都需要进行一次自校准测量。自校准功能可对编码器安装的误差进行自整定，使每个编码器都拥有独一无二的磁场标定数据，提供最佳的测量精度。

Encoders require a self-calibration measurement after installation. The self-calibration function can self-tune the error of the encoder installation, so that each encoder has unique magnetic field calibration data, providing the best measurement accuracy.

校准功能：使用校准功能前要确保编码器已安装固定好。点击“校准”按钮，进入校准界面。先转动电机，再选择“单次校准”或“重复校准”，然后点击“获取数据”按钮进行校准，推荐转速在 0.25~1rev/s，最好是恒速，当进度条结束后会自动显示波形。若提示“行程不完整，如有限位，请使用部分校准”则适当调大电机转速，或调大速度档位（速度档位越大所需的校准速度越慢）。直到提示“行程内校准通过，参数已成功保存”则校准结束。通过观察左侧的误差判断是否通过。

当“单次校准”误差范围>80%，建议选用“重复校准”进行再次校准。

Calibration function: Before using the calibration function, make sure that the encoder is installed and fixed. Click "Calibration" to enter the calibration interface. Rotate the motor first, then select "Single calibration" or "Repeat calibration", and then click "Acquire Data" to calibrate. The recommended speed is 0.25~1 rev/s, preferably at a constant speed. After the progress bar is completed, the waveform will be displayed automatically. If it prompts "Incomplete stroke, such as limited position, please use partial calibration", increase the motor speed appropriately, or increase the speed gear (the larger the speed gear, the slower the required calibration speed). The calibration is finished when it prompts "In stroke calibration passed, parameters have been saved successfully". Judge whether the result is passed by observing the error on the left.

When the "Single calibration" error range is larger than 80%, it is recommended to click "Repeat calibration" to calibrate again.

测量功能：对当前所保存在编码器中的校准参数进行测量是否能符合当前的安装环境。“单次校准”和“重复校准”复选框同时未选中时为测量功能。测量的操作步骤和校准一样。通过观察左侧的误差判断是否通过。

Measurement function: The calibration parameters currently stored in the encoder are measured to make sure whether it is compliance with the installation. Measurement functions when both the "Single calibration" and "Repeat calibration" checkboxes are unchecked. The operation steps for measurement are the same as for calibration. By observing to determine whether the error on the left is passed.



图 11-4 编码器校准与测量

Figure 11-4 Encoder calibration and measurement

判定标准：校准和测量波形判定标准都是正负误差百分比小于 90%。

Judgment criteria: The judgement criteria of calibration and measurement waveform are that the max and min value percentage is less than 90%.

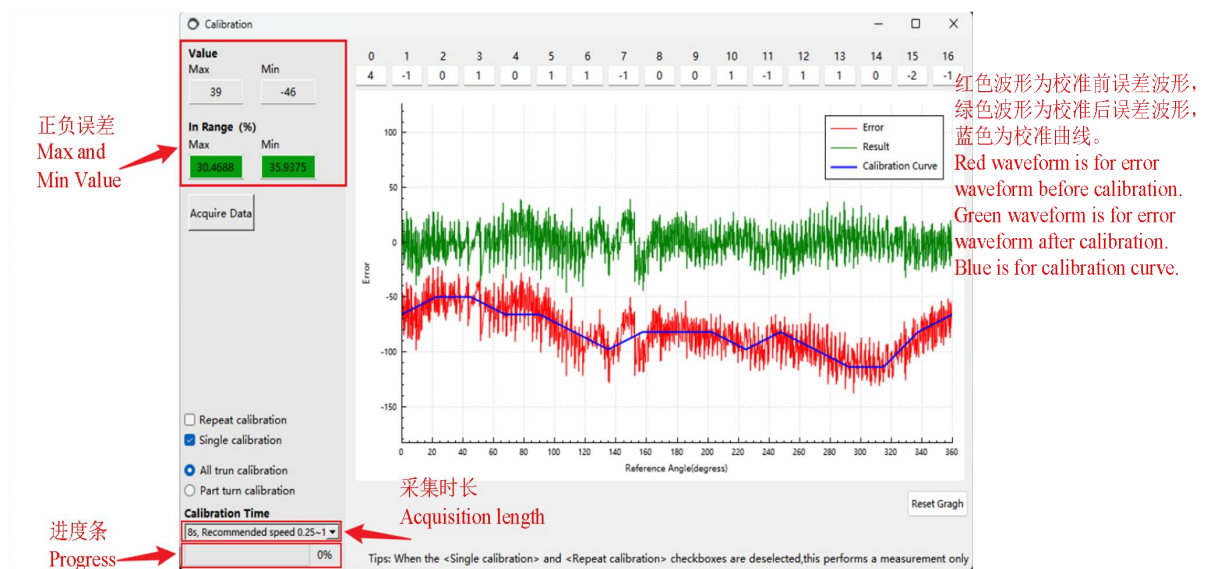
## 11.5 校准波形异常原因

### Causes of abnormal calibration waveforms

#### 11.5.1. 校准无法通过

##### Calibration failed

校准无法通过一般有以下几种情况：



第一种，整体误差幅度超出范围。

Generally, there are several situations for calibration failed:

The first type is the overall margin of error is out of range.

一般出现这种波形是由于结构安装导致，检查或重新调整读头与码盘安装距离，参考第三章机械安装说明。

Generally, this kind of waveform is caused by the structural installation. Check or readjust the installation distance between the read head and the code disc. Refer to Chapter 3 Mechanical Installation Instructions.



图 11-5 整体误差超出范围

Figure 11-5 Overall error out of range

第二种，波形出现尖峰。

The second type is that a spike appears in the waveform.

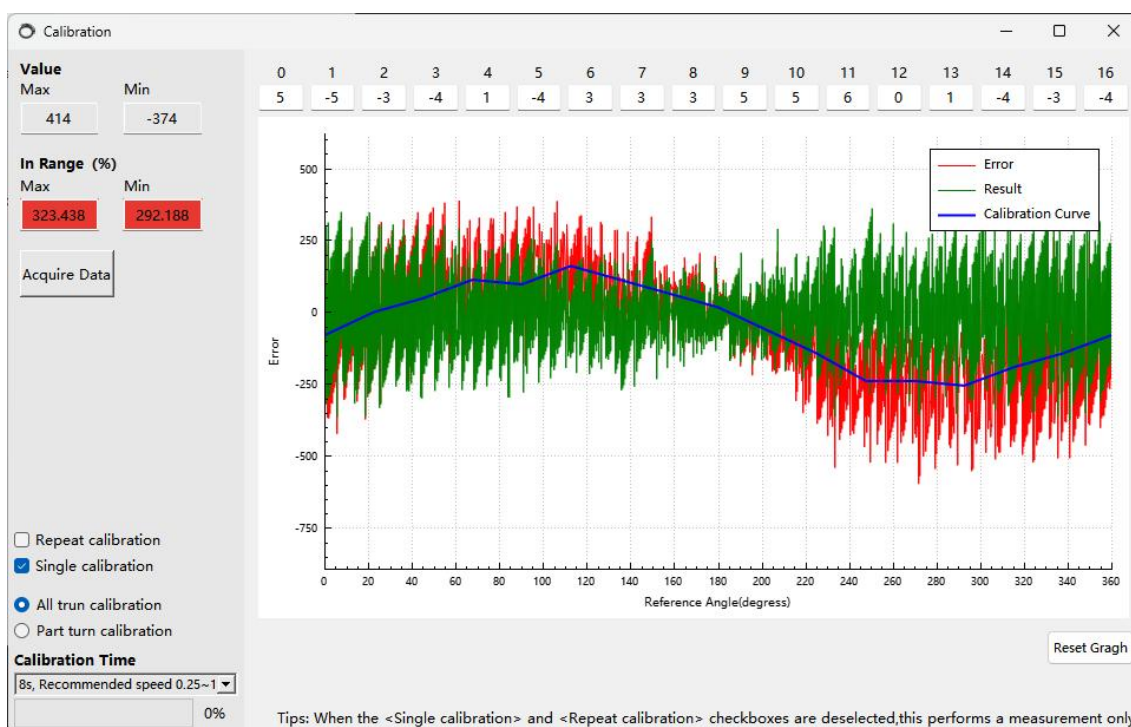
一般出现这种波形需要检查码盘是否刮伤，或者码盘表面是否沾上了铁屑等干扰磁场的物质。

Generally this waveform needs to check whether the ring scratches, or whether its surface is covered with iron chips and other magnetic interference substances.





图 11-6 尖峰波形

Figure 11-6 Spike waveform

第三种，异常波形。出现该情况通过以下方式进行分析判断。

The third type is abnormal waveform, whose situation can be analyzed and judged in the following ways.

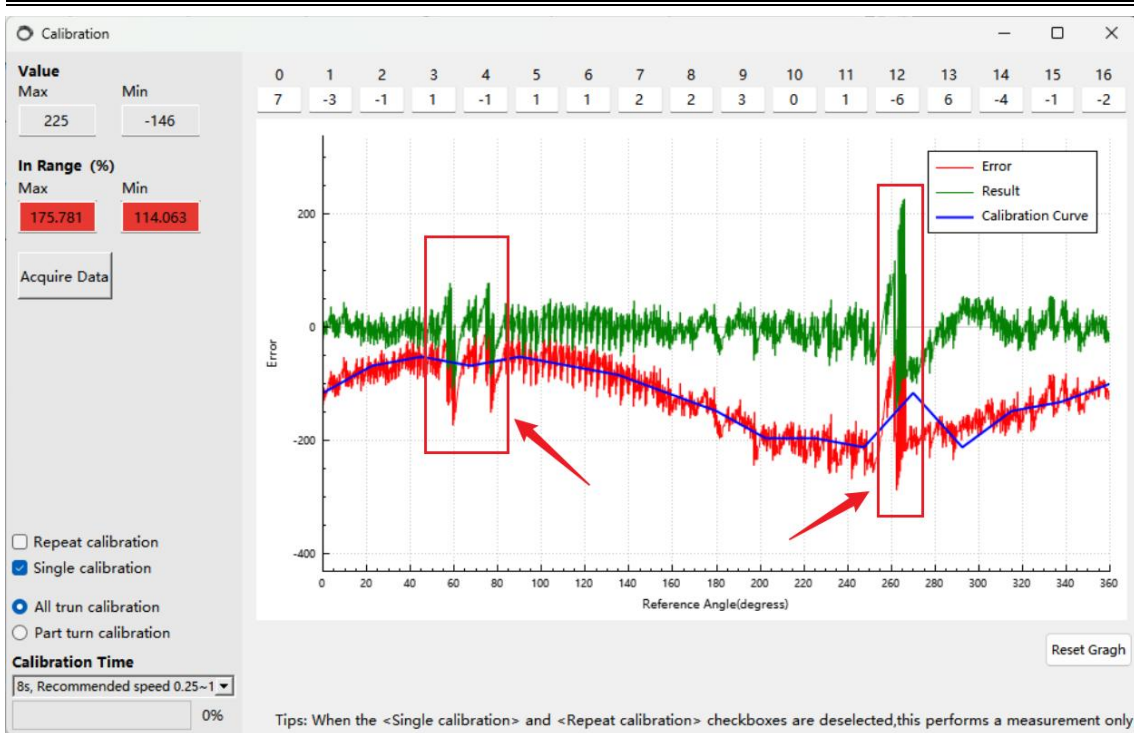
1、检查供电是否满足使用范围内的电压。

Check whether the power supply meets the voltage within the range of use.

2、检查编码器和码盘是否在转动时出现抖动未固定好。

Check whether the encoder and ring are shaken when they rotate because they are not fixed.

3、检查安装距离是否过远。

Check whether the installation distance is too far.

4、检查码盘磁道是否受损。

Check whether the track of ring is damaged.



图 11-7 异常校准图形

Figure 11-7 Abnormal calibration graph

### 11.5.2. 径向误差对校准影响

#### Radial error on calibration

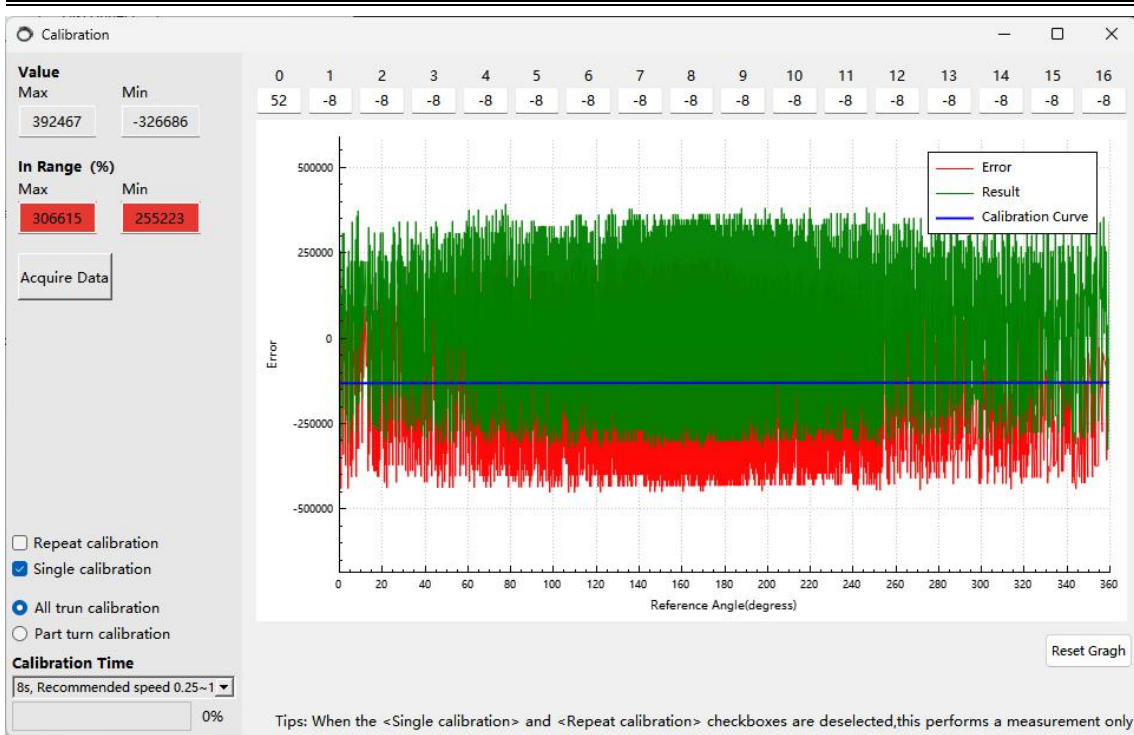
码盘的精确安装是确保编码器整体达到良好精度的关键，尤其径向安装误差，对编码器精度是十分明显的，以下波形为同一环境下不同径向误差对校准的影响。

Precise centering of the magnetic ring is the key to good overall accuracy, in particular, the radial installation error is very obvious to the accuracy of the encoder. The following waveform is the influence of different radial errors on the calibration in the same environment.



图 11-8 径向误差偏移约 0.02mm 校准波形

Figure 11-8 Radial error offset about 0.02mm calibration waveform

径向误差偏移约 0.02mm 校准波形，波形整体均处于正常范围之内。

The radial error is offset by about 0.02mm to calibrate the waveform, and the entire waveform is within the normal range.

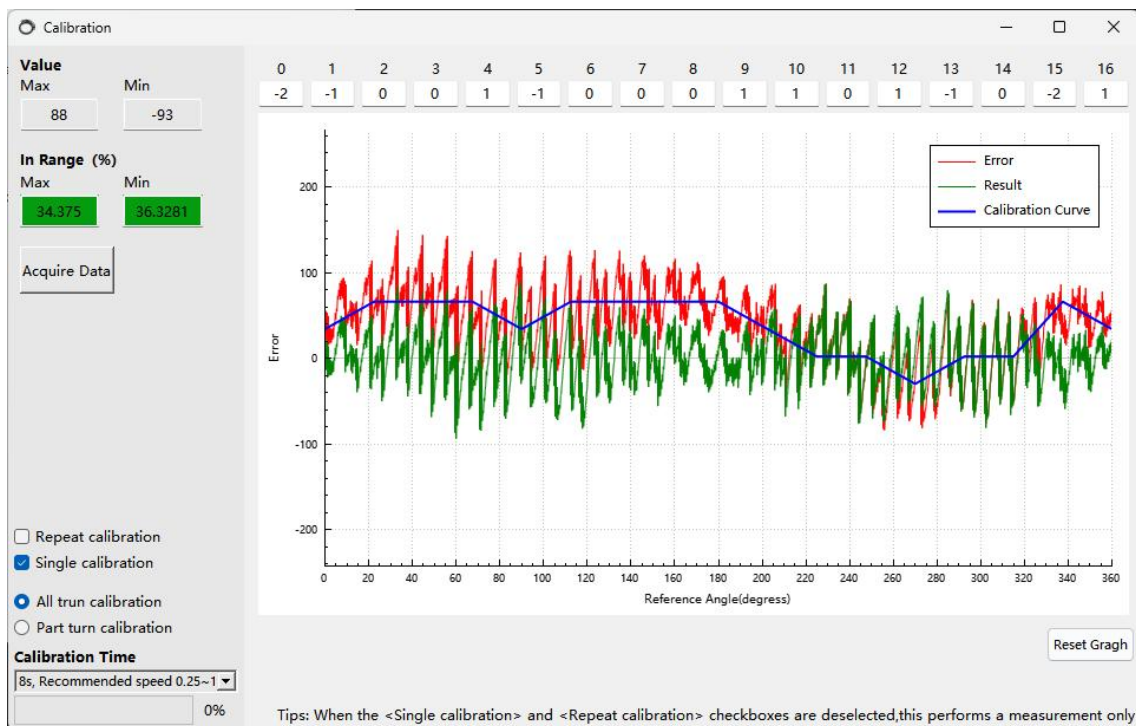

图 11-9 径向误差偏移 0.2mm 校准波形误差

Figure 11-9 Radial error offset 0.2mm calibration waveform error

径向误差偏移 0.2mm 校准波形误差，误差虽仍处于合格范围内，但相比在径向误差为 0.02mm 下，校准后误差波形明显发生偏移如绿色曲线所示，处于 90° 与 270° 位置，误差整体幅度增加。

The radial error deviation is 0.2mm calibration waveform error. Although the error is still within the qualified range, the calibration error waveform deviates significantly compared with the radial error of 0.02mm. After calibration, the error waveform obviously significantly as shown in the green curve, at positions 90 ° and 270 ° , and the overall amplitude of the error increases.

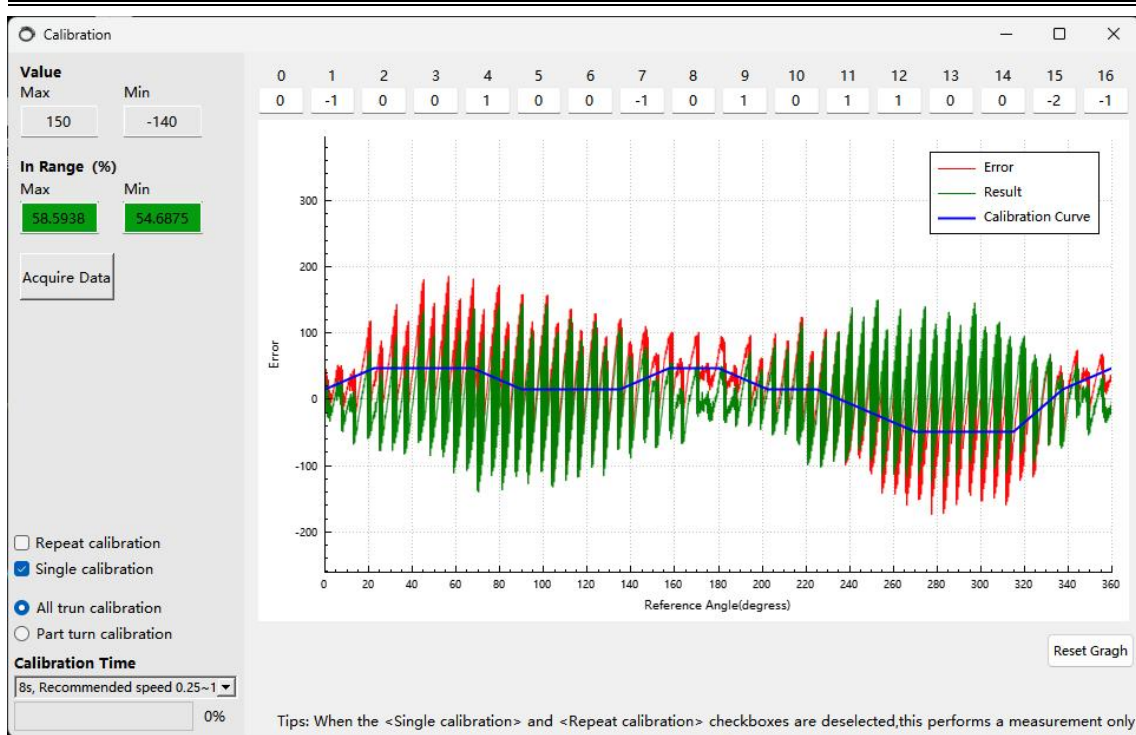
## 11.6 固件版本升级

### Firmware version upgrade

eCoder 固件版本定义规则如下图 11-10 所示。

The definition of eCoder firmware version are as shown in Figure 11-10.



图 11-10 编码器固件版本定义规则

Figure 11-10 Encoder firmware version definition

目前 eCoder 系列编码器固件的分类如下表 11-1 所示。

The current classification of the eCoder series encoder firmware is as shown in Table 11-1.

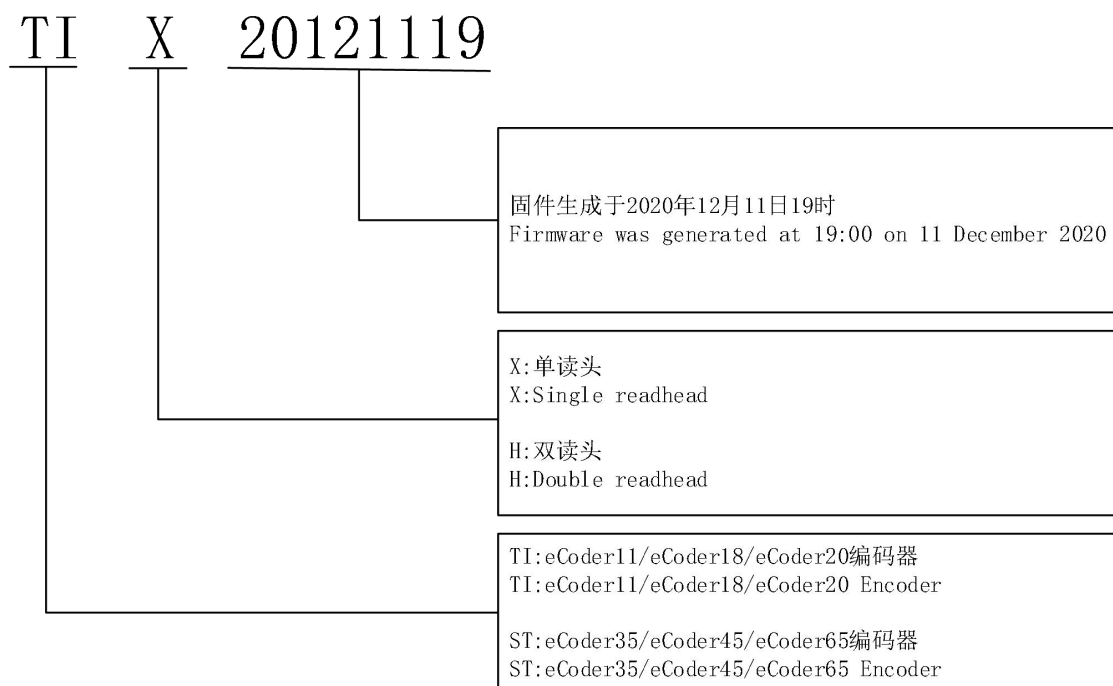
表 11-1 固件版本类型

Table 11-1 Firmware version type

固件文件 Firmware file	支持编码器类型 Supported encoder types
TIX20121119.bin	eCoder11/eCoder18/eCoder20
STX20121119.bin	eCoder35/eCoder45/eCoder65
STH20121119.bin	eCoder35H

## 11.7 固件升级

### Firmware upgrade

升级步骤如下图 11-11~图 11-12 所示。

The upgrade steps are shown in Figure 11-11 and Figure 11-12.



图 11-11 升级选项

Figure 11-11 Upgrade button

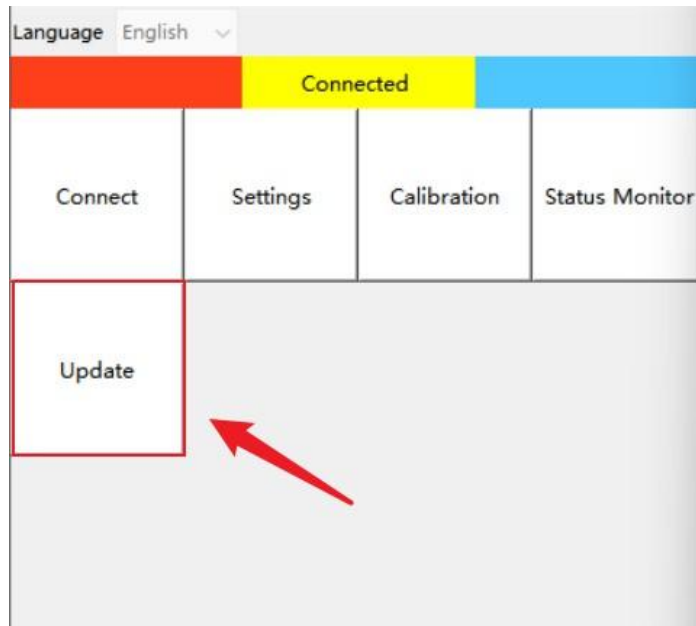

图 11-12 升级过程

Figure 11-12 Upgrade process

等待升级完成，升级完成后，将会提示升级成功，如下图 11-13 所示。

Wait for the upgrade to complete. After the upgrade is completed, it will prompt “Upgrade succeeded, please restart the eCoder”, as shown in Figure 11-13 .

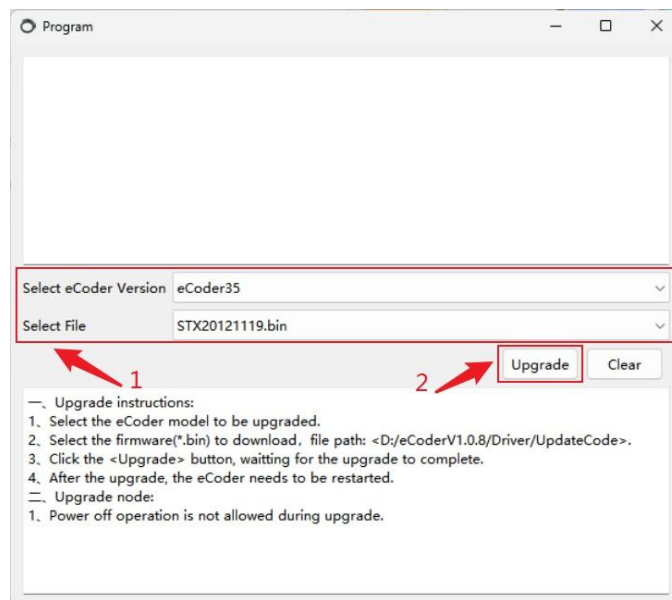

图 11-13 升级完成提示

Figure 11-13 Prompt of upgrade completion

升级成功后断电重启，重新连接编码器，检查升级后固件版本，如图 11-14 所示。

Power off and restart after successful upgrade. Reconnect the encoder, and check the upgraded firmware version, as shown in Figure 11-14.

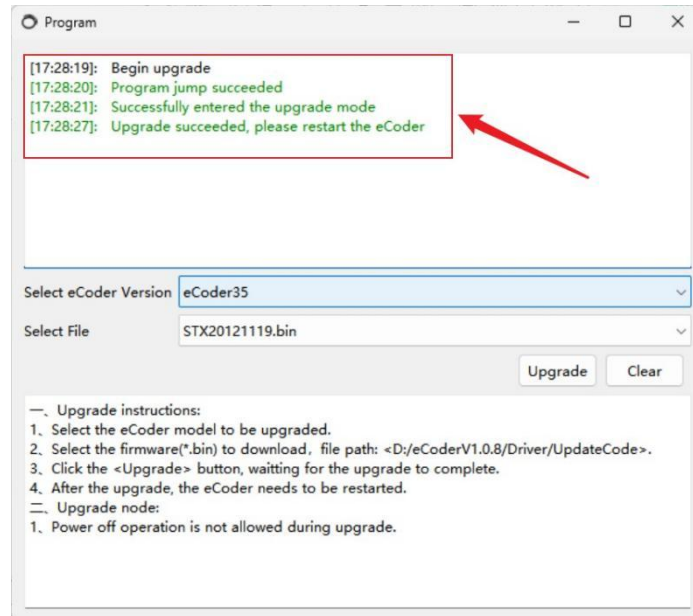



图 11-14 升级成功后重新连接编码器确认固件版本

Figure 11-14 Reconnect the encoder after successful upgrade to confirm firmware version

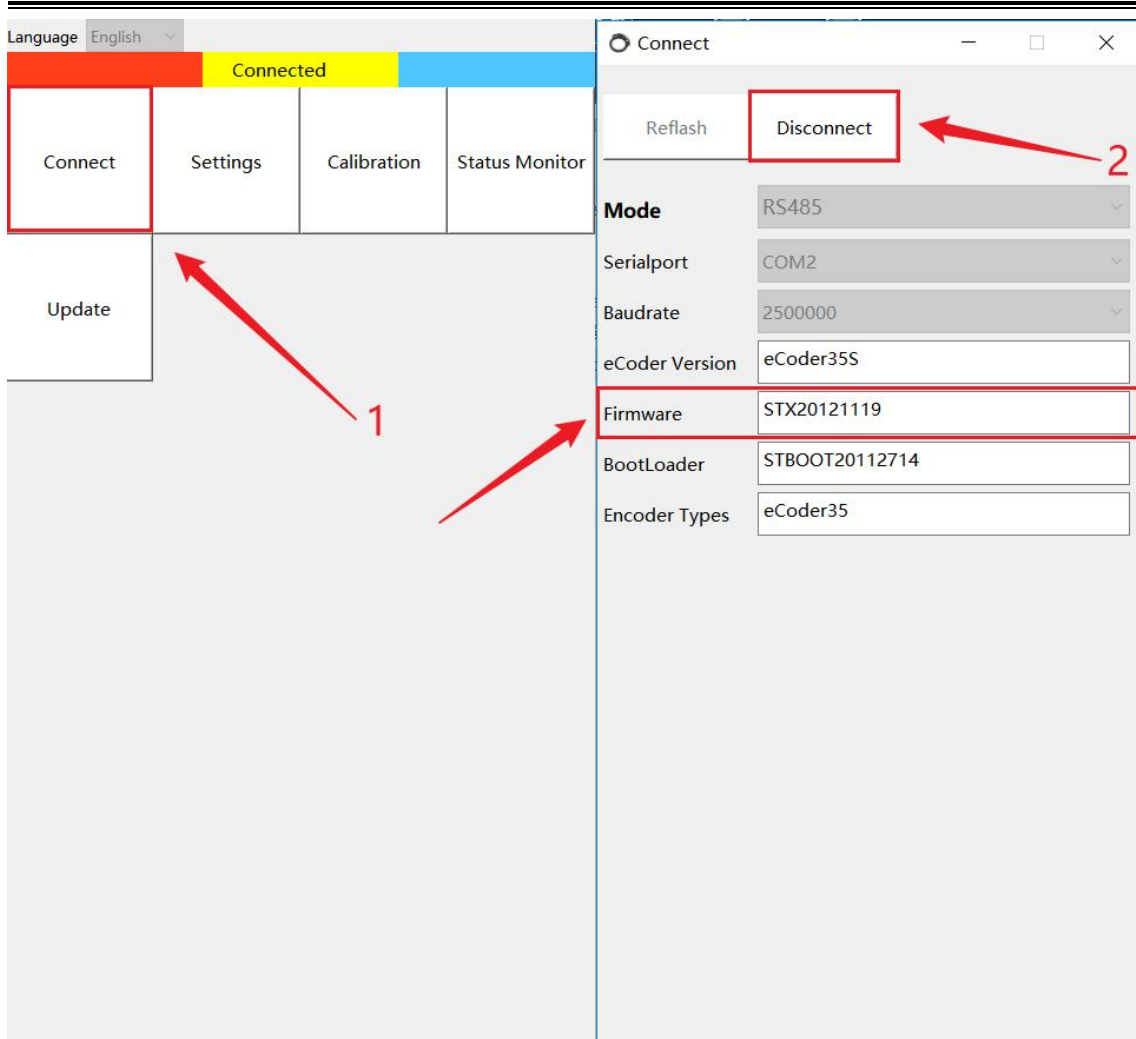

## 第十二章 异常处理

### Chapter 12 Exception Solutions

在编码器上位机状态界面，点击“状态监控”可以实时获取编码器状态信息。

On the encoder host computer status interface, click "Status Monitor" to obtain the encoder status information in real time.



图 12-1 编码器状态读取

Figure 12-1 Encoder status read

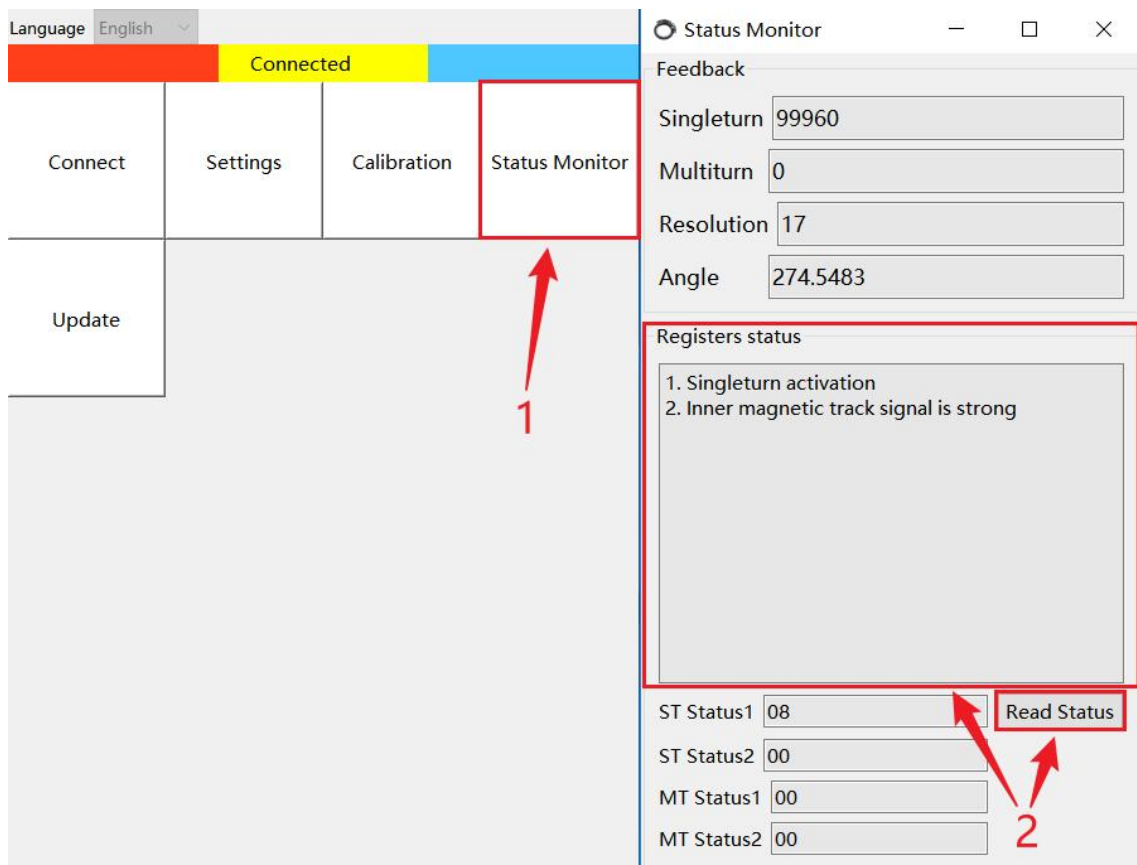

表 12-1 异常问题处理方法

Table 12-1 Exception handling method

提示信息 Messages	“外磁道信号弱”或“内磁道磁场弱” “external magnetic field signal too weak” or “internal magnetic field signal too weak”
一般原因 Causes	读头与码盘安装距离过远 The readhead is too far to the ring.
解决措施 Solutions	重新调整安装距离 Readjust the installation distance
提示信息 Messages	“外磁道信号强”或“内磁道磁场强” “external magnetic field signal too strong” or “internal magnetic field signal too strong”
一般原因 Causes	读头与码盘安装距离过近 The readhead is too close to the ring.
解决措施 Solutions	重新调整安装距离 Readjust the mounting distance
提示信息 Messages	“单圈启动错误”或“多圈通讯错误”或“多圈同步错误” “Singleturn start error” or “Multiturn communication error” or “Multiturn synchronization error”
一般原因 Causes	读取多圈出现问题 Read multiturn error
解决措施 Solutions	查看多圈报错再定性问题 Check the multiturn error and re-qualify the problem
提示信息 Messages	“单圈计数错误” “Singleturn counter error”
一般原因 Causes	编码器未经过校准；采集位置信息异常 Uncalibrated encoder causes abnormal collected position information
解决措施 Solutions	重新校准；查看供电确定供电无异常，检查磁条是否无损伤 Recalibrate and check power supply, to make sure that the power supply is normal, and check whether the magnetic strip is not damaged.
提示信息 Messages	“多圈同步错误” “Multiturn synchronization error”
一般原因 Causes	多圈数据存在异常 Multiturn data abnormal
解决措施 Solutions	重新执行多圈复位 “Re-execute the multiturn reset”
提示信息 Messages	“游标计数周期错误” “Nonius period count error”
一般原因 Causes	采集位置信息异常 Position information acquisition abnormal
解决措施 Solutions	查看供电确定供电无异常，检查磁条是否无损伤，然后重新进行校准矫正。 Check the power supply to make sure that the power supply is normal, check whether the magnetic strip is not damaged, and then re-calibrate it.
提示信息 Messages	“内部配置 CRC 错误” “Internal configuration CRC error”
一般原因 Causes	单圈配置信息出错 Singleturn configuration information is incorrect
解决措施 Solutions	配置参数不正确，需要返厂重写参数 Configuration parameters error, need to return to factory to rewrite the parameters.



---

提示信息 Messages	“多圈掉电标记”或“多圈复位标记” “Multiturn power-off mark” or “Multiturn reset mark”
一般原因 Causes	第一次上电，或发生过在 5V 不供电情况下，不接电池。 The battery is not need to connect for the first time when the power is on, or when 5V is powered off.
解决措施 Solutions	执行多圈复位清除错误即可。 Perform a multiturn reset to clear the error.

---

提示信息 Messages	“电池电压低于预警值 (<3.15V)”或“电池电压低于报警值 (<3.05V)”或“电池电压错误” “Battery voltage below warning value (<3.15V)” or “Battery voltage below alarm value (<3.05V)” or “Battery voltage error”
一般原因 Causes	电池接线或电池电压异常 Abnormal battery wiring or battery voltage
解决措施 Solutions	检查电池 Check battery

---

提示信息 Messages	“IIC 通讯错误”或“内部计数器 1 错误”或“内部计数器 2 错误” “IIC communication error” or “Internal counter 1 error” or “Internal counter 2 error”
一般原因 Causes	存储配置参数期间损坏或读取的通讯受到干扰 Damage during storage of configuration parameters or interference with the read communication
解决措施 Solutions	需要相关技术人员分析 It requires analysis by the relevant technician

---

提示信息 Messages	“芯片内部 CRC 计算错误”或“芯片内部 CRC 配置错误”或“多圈芯片启动错误” “Internal chip CRC calculation error” or “Internal chip CRC configuration error” or “Multiturn chip start error”
一般原因 Causes	多圈配置信息出错 Multiturn configuration information error
解决措施 Solutions	配置参数不正确，需要返厂重写参数 Configuration parameters error need to return to factory to rewrite the parameters

---

提示信息 Messages	“磁信号幅值错误”或“磁信号错误”或“发生过无磁信号工作状态” “Magnetic signal amplitude error” or “Magnetic signal error” or “No magnetic signal status has occurred”
一般原因 Causes	编码器脱离过码盘，或者断电期间发生过超速移动或电池接触不良 The encoder has been disconnected from the ring, or there has been an overspeed movement during a power off or poor battery contact
解决措施 Solutions	检查电池和检查安装 Check the battery and the installation

---

提示信息 Messages	内部 12 位传感器信号错误 Internal 12-bit sensor signal error
一般原因 Causes	传感器信号采集异常 Sensor signal acquisition abnormal
解决措施 Solutions	严格按照“第三章机械安装说明”进行安装 Strictly follow the "Chapter 3 Installation instructions" for installation

---



# 第十三章 附录

## Chapter 13 Appendix

### 13.1 产品命名规则

#### Part numbering

	eCoder	35	M - R	20B
产品类型 Product type				
eCoder - 零差云控编码器系列前缀 ZeroErr encoder series				
码盘内径 Inner diameter				
11 - 11mm				
18 - 18mm				
20 - 20mm				
35 - 35mm				
45 - 45mm				
65 - 65mm				
35H - 35mm				
多圈计数功能 Multiturn counter function				
S - 无多圈记忆功能 Singleturn counter function				
M - 带多圈记忆功能 Multiturn counter function				
接口类型 Interface type				
R - RS485 通讯 RS485 Communication				
分辨率 Resolution				
17B - 17 位分辨率 (支持所有型号) 17 bits per resolution (all models supported)				
18B - 18 位分辨率 (支持所有型号) 18 bits per resolution (all models supported)				
19B - 19 位分辨率 (支持所有型号) 19 bits per resolution (all models supported)				
20B - 20 位分辨率 (仅支持 eCoder35, eCoder45, eCoder65, eCoder35H) 20 bits per resolution (eCoder35, eCoder45, eCoder65, eCoder35H only)				
21B - 21 位分辨率 (仅支持 eCoder35H) 21 bits per resolution (eCoder35H only)				

## 13.2 配件

### Accessories



RS485 连接线 Connector: 30cm



eCoder 调试器 eCoder to PC Connector



3.6V 多圈电池 Multiturn battery



定位销钉 Locating pin:  $\phi 2*15\text{mm}$



十字固定螺钉 Cross fixed screw: M2\*5mm



内六角固定螺钉 Inner allen screw: M2.5\*5mm



---

## 总部 Head Office

---

深圳市零差云控科技有限公司

Zeroerr Control Co.,Ltd.

地 址 Address: 中国广东省深圳市宝安区沙井街道坐岗社区中日龙路 10 号 3 楼

3/F, No.10, Zhongrilong Road, Bogang Community, Shajing Street, Bao'an District,  
ShenZhen City, Guangdong Province, P.R.China

售前咨询 Sales support: 134 8079 6208

136 0260 7132

邮 箱 Email: sales@zeroerr.cn

Sales Email: marketingdirector@zeroerr.cn

售后支持 Technical support: 178 2067 6603

400 893 0660

投诉建议 Advice: network@zeroerr.cn

---

## 全球技术支持 Global Support

---

请访问我们的网站，联系您最近的销售代表。

Visit our website to contract your nearest sales representative.

www.zeroerr.cn



## 声明

本产品的设计和使用不能超出本产品数据表中明确规定的环境限制和操作参数。本产品不适用于医疗、军事、航空航天、汽车或石油和天然气应用或任何产品故障可能导致严重环境或财产损失、人身伤害或死亡的安全关键应用。此类应用中的任何使用必须经卖方书面明确同意，并受卖方自行决定施加的附加条款的约束。在此类应用中使用产品的风险由买方自行承担，买方将赔偿卖方及其关联公司因此类使用而产生的任何责任、损失、损害或费用。本数据表中包含的信息来自受控实验室条件下的产品测试，其报告的数据受规定的公差和变化的约束，如果没有规定，则公差和变化与通常的测试惯例和测试方法一致。该产品在实验室条件之外的性能，包括当一个或多个操作参数处于其最大范围时，可能不符合产品的数据表。此外，产品数据表中的信息不反映产品在买方或其客户可能将产品置于任何应用、最终用途或操作环境中的性能。卖方及其附属公司对该产品是否适合买方的应用、使用、最终产品、工艺或与任何其他产品的组合，或对买方或其客户在使用该产品时可能获得的任何结果，不作任何建议、保证或陈述。买方应使用自己的知识、判断、专业知识和测试为买方的应用、最终用途或操作环境选择产品，不应依赖卖方或其关联公司的任何口头或书面声明、陈述或样品。除卖方条款和销售条件中明确规定的保证外，卖方对产品不作任何明示或暗示的保证，包括任何特定目的的适销性或适用性保证，均被否认和排除。所有销售受卖方的独家销售条款和条件约束，卖方可根据要求提供，在每种情况下，均可通过参考纳入此协议，并为独家销售条款。买方无权作出任何扩展或扩展产品的环境限制和操作参数，或暗示在数据表上明确规定之外的允许使用或由卖方书面同意的声明或陈述的任何行为。

零差云控已作出相当大的努力以确保本文件的内容在发布之日是正确的，但未对内容作出保证或声明。零差云控不包括对本文件中任何不准确的地方所产生责任。

深圳市零差云控科技有限公司

## Declaration

Our product is not designed or intended for use outside the environmental limitations and operating parameters expressly stated on the product's datasheet. Products are not designed or intended for use in medical, military, aerospace, automotive or oil, gas applications or any safety-critical applications where a failure of the product could severe serious environmental or property damage, personal injury or death. Any use in such applications must be specifically agreed to seller in writing, and is subject to such additional terms as the seller may impose in its sole discretion. Use of products in such applications is at buyer's own risk, and buyer will indemnify and hold harmless seller and its affiliates against any liability, loss, damage or expense arising from such use. Information contained in this datasheet was derived from product testing under controlled laboratory conditions and data reported thereon is subject to the stated, then to tolerances and variations, or if none are stated, then to tolerances and variations consistent with usual trade practices and testing methods. The product's performance outside of laboratory conditions, including when one or more operating parameters is at its maximum range, may not conform to the product's datasheet. Further, information in the product's datasheet does not reflect the performance of the product in any application, end-use or operating environment buyer or its customer may put the product to. Seller and its affiliates make no recommendation, warranty or representation as to the suitability of the product for buyer's application, use, end-product, process or combination with any other product or to any results buyer or its customer might obtain in their use of the product. Buyer should use its own knowledge, judgment, expertise and testing in selecting the product for buyer's application, and-use and/or operating environment, and should not rely on any oral or written statement, representation, or samples made by seller or its affiliates for any purpose. Except for the warranties expressly set forth in the seller's terms and conditions of sale, seller makes no warranty express or implied with respect to the product, including any warranty of merchantability or fitness for any particular purpose, which are disclaimed and excluded. All sales are subject to seller's exclusive terms and conditions of sales which, where the seller is another person, are available on request, and in each case, are incorporated herein by reference, and are exclusive terms of sale. Buyer is not authorized to make any statements or representations that expand the environmental limitations and operating parameters of the products, or which imply permitted usage outside of that expressly stated on the datasheet or agreed to in writing by seller.

Zeroerr has made considerable effort to ensure the content of this document is correct at the date of publication but makes no warranties or representations regarding the content .Zeroerr excludes liability, howsoever arising, for inaccuracies in this document.

Shenzhen Zeroerr Control Co.,Ltd.